

**MINIMILL**

Nut- und Formzirkularfräsen

groove milling by circular interpolation

**Typ Z22**

metrisches ISO-Gewinde, Vollprofil, innen

metric ISO-thread, full profile, internal

ab Gewindegröße M24 x 1,5

starting at thread size M24 x 1,5

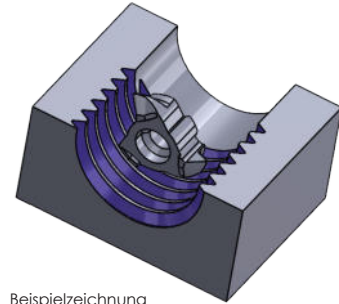
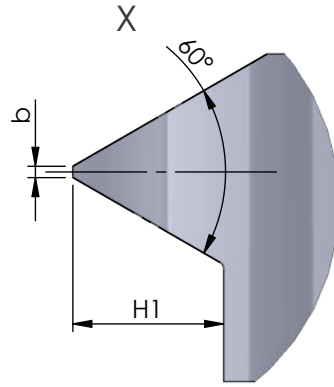
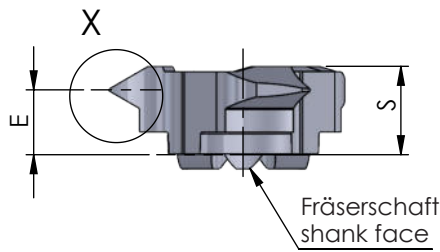
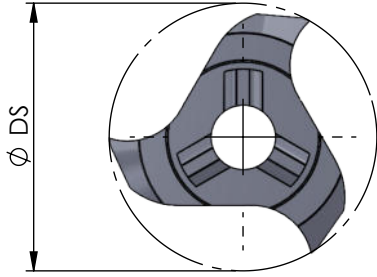

Beispielzeichnung  
exemplary application

Abmessungen in mm

dimensions in mm

Bestellnummer part number	min. Gewindegröße min. thread size	Steigung P pitch P	S	E	Ø DS	b	H1	Zähnezahl number of teeth	K10F AL41F P18C	für Fräaserschaft for milling shank
Z22.0815.02	M24	1.50	5.85	4.8	21.7	0.19	0.81	3	●	ZH22...
Z22.0917.02	M27	1.75	5.85	4.7	21.7	0.22	0.95	3	●	
Z22.1020.02	M27	2.00	5.85	4.6	21.7	0.25	1.08	3	●	
Z22.1630.02	M30	3.00	5.85	4.3	21.7	0.37	1.62	3	●	
Z22.1835.02	M30	3.50	5.85	4.0	21.7	0.43	1.89	3	●	
Z22.2140.02	M33	4.00	5.85	3.9	21.7	0.50	2.16	3	●	
Z22.2445.02	M33	4.50	5.85	3.7	21.7	0.56	2.43	3	●	

Weitere HM Sorten können Sie in der Sortenübersicht im Kapitel "Technische Hinweise" und der Preisliste finden.

Bestellbeispiel:  
für Sorte AL41F:  
Z22.0815.02/AL41F

More carbide grades you can find in the grades summary in the chapter "technical instructions" and in the price list.

order-example:  
grade AL41F:  
Z22.0815.02/AL41F