

MINIMILL

Nut- und Formzirkularfräsen

groove milling by circular interpolation

Typ Z622

metrisches ISO-Gewinde, Vollprofil, innen

metric ISO-thread, full profile, internal

ab Gewindegröße M24 x 1,5

starting at thread size M24 x 1,5

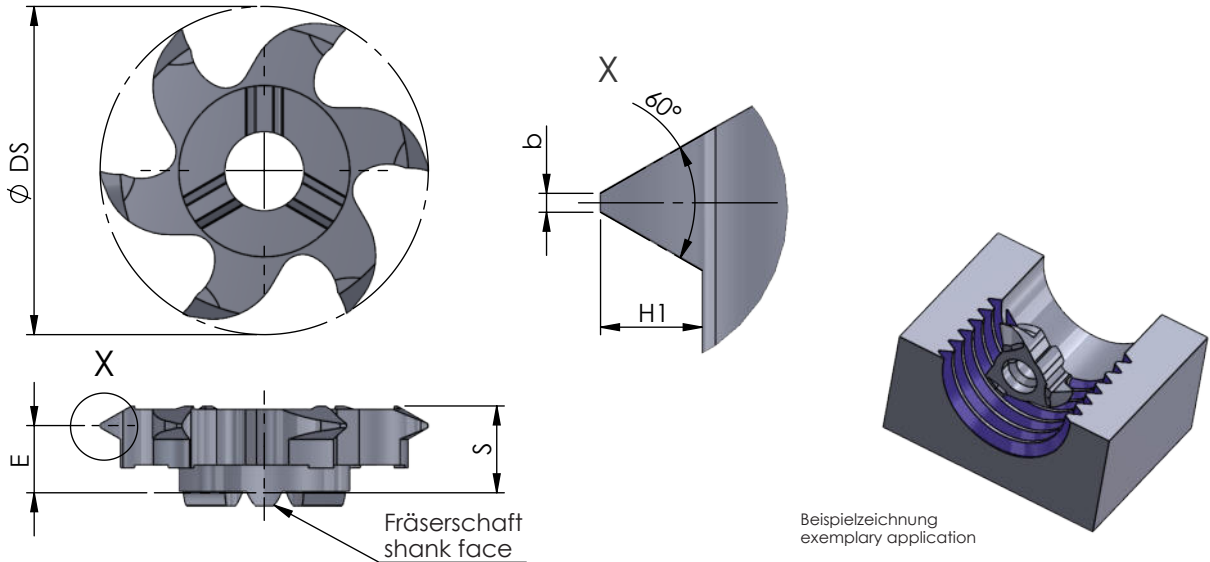

Abmessungen in mm

dimensions in mm

Bestellnummer part number	min. Gewindegröße min. thread size	Steigung P pitch P	S	E	$\varnothing DS$	b	H1	Zähnezahl number of teeth	K10F AL41F P18C	für Fräseschaft for milling shank
Z622.0815.02	M24	1.50	6.2	5.3	21.7	0.19	0.81	6	●	ZH22...
Z622.0917.02	M27	1.75	6.2	5.2	21.7	0.22	0.95	6	●	
Z622.1020.02	M27	2.00	6.2	5.0	21.7	0.25	1.08	6	●	
Z622.1630.02	M30	3.00	6.2	4.8	21.7	0.37	1.62	6	●	
Z622.2140.02	M33	4.00	6.2	4.4	21.7	0.50	2.16	6	●	

Weitere HM Sorten können Sie in der Sortenübersicht im Kapitel "Technische Hinweise" und der Preisliste finden.

Bestellbeispiel:
für Sorte AL41F:
Z622.0815.02/AL41F

More carbide grades you can find in the grades summary in the chapter "technical instructions" and in the price list.

order-example:
grade AL41F:
Z622.0815.02/AL41F