

# MINIMILL

Nut- und Formzirkularfräsen

groove milling by circular interpolation

# Typ Z16

Whitworth-Gewinde, Vollprofil, innen

Whitworth thread, full profile, internal

ab Gewindegröße G 5/8"

starting at thread size G 5/8"

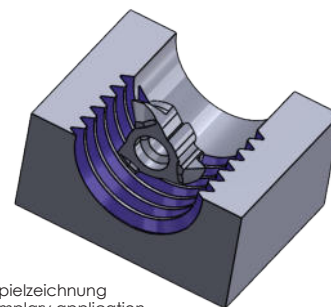
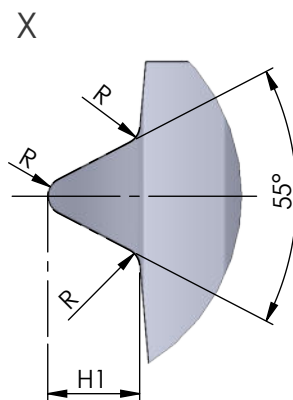
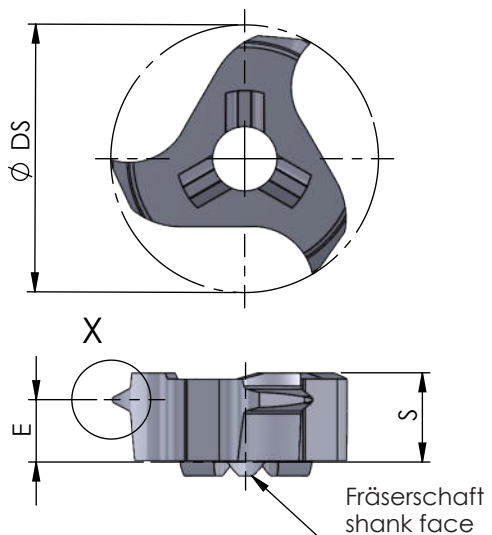

Beispielzeichnung  
exemplary application

Abmessungen in mm

dimensions in mm

Bestellnummer part number	min. Gewindegröße min. thread size	Gang / Zoll threads / inch	S	E	Ø DS	H1	R	Zähnezahl number of teeth	Material			für Fräaserschaft for milling shank
									K10F	AL41F	P18C	
Z16.5514.02	G 5/8"	14	4.5	3.0	15.7	1.17	0.24	3	●			
Z16.5511.02	G 1"	11	4.5	2.8	15.7	1.48	0.31	3	●			ZH14...

Weitere HM Sorten können Sie in der Sortenübersicht im Kapitel "Technische Hinweise" und der Preisliste finden.

Bestellbeispiel:  
für Sorte AL41F:  
Z16.5514.02/AL41F

More carbide grades you can find in the grades summary in the chapter "technical instructions" and in the price list.

order-example:  
grade AL41F:  
Z16.5514.02/AL41F