

MINIMILL

Nut- und Formzirkularfräsen

groove milling by circular interpolation

Typ Z614

Vorwärts- und Rückwärtsfasen

forward & backward chamfering

D min. 14 mm

D min. 14 mm

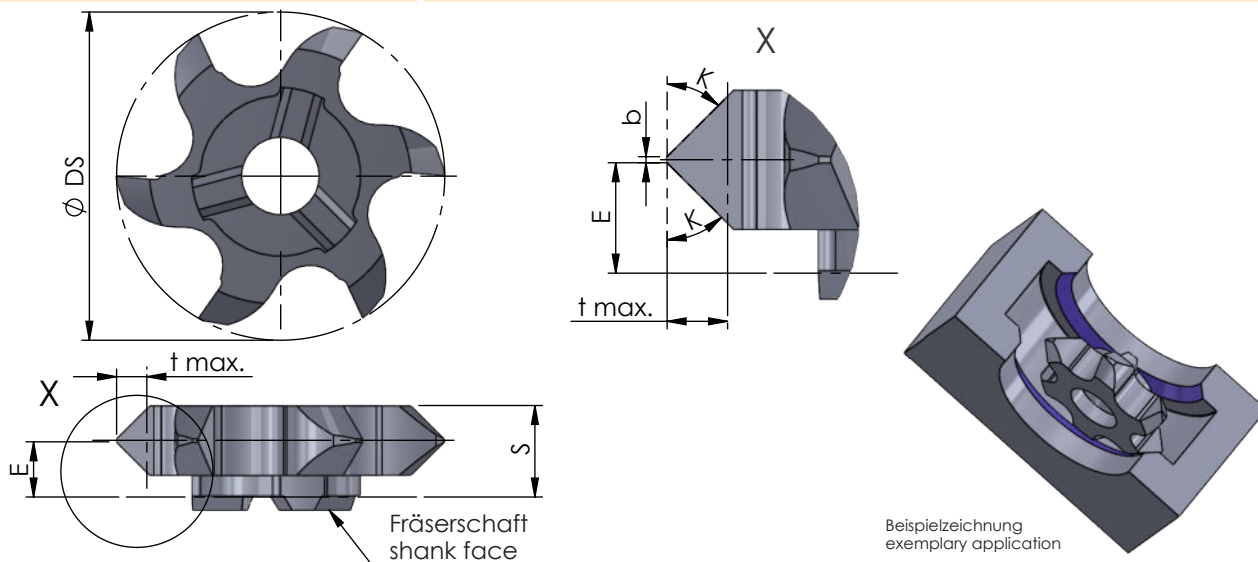

Abmessungen in mm

dimensions in mm

Bestellnummer part number	K	D min.	S	E	$\varnothing DS$	b	t max.	Zähnezahl number of teeth	Material			für Fräseschaft for milling shank
									K10F	AL41F	P18C	
Z614.1515.02	15°	14	4.6	2.3	13.7	0.2	0.35	6	●			
Z614.2020.02	20°	14	4.6	2.3	13.7	0.2	0.45	6	●			
Z614.3030.02	30°	14	4.6	2.3	13.7	0.2	0.7	6	●			
Z614.4545.02	45°	14	4.6	2.3	13.7	0.2	1.8	6	●			ZH14...

Weitere HM Sorten können Sie in der Sortenübersicht im Kapitel "Technische Hinweise" und der Preisliste finden.

Bestellbeispiel:
für Sorte AL41F:
Z614.1515.02/AL41F

More carbide grades you can find in the grades summary in the chapter "technical instructions" and in the price list.

order-example:
grade AL41F:
Z614.1515.02/AL41F