

ULTRAMINI

Bohrungsbearbeitung
ab $\varnothing 0.2$ mm

grooving, boring and profiling
starting at $\varnothing 0.2$ mm

Typ 050

Audreihen und Kopieren

D min. 0.2 - 9.8 mm

boring and profiling

D min. 0.2 - 9.8 mm

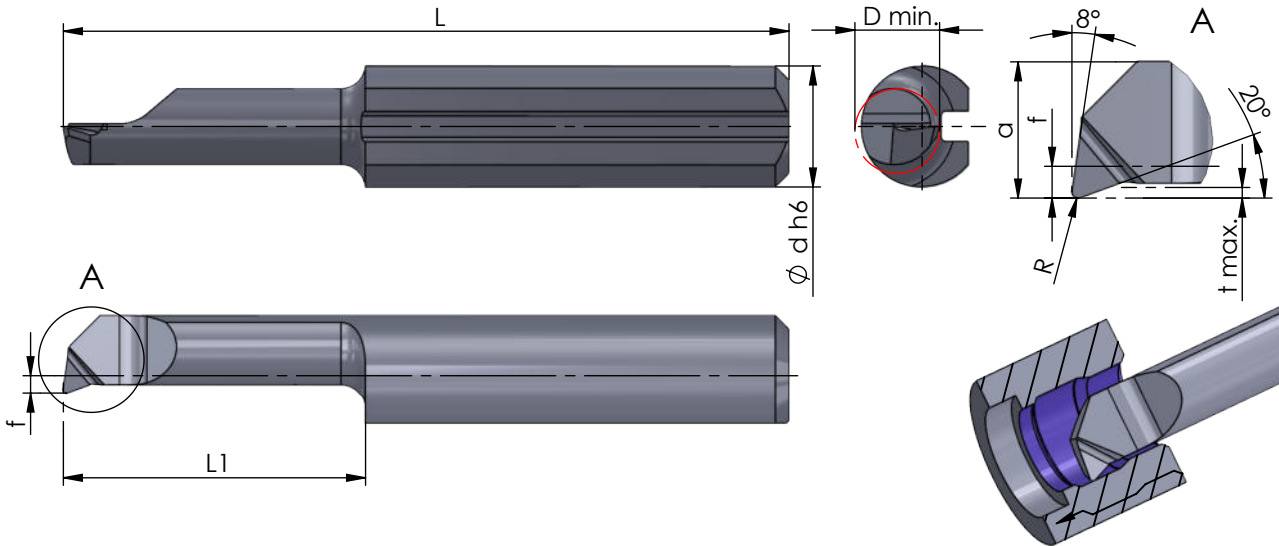

Rechts (R): wie gezeichnet
Links (L): spiegelbildlich

righthand (R): as shown
lefthand version (L): mirror image

Abmessungen in mm

dimensions in mm

Bestellnummer part number	R	f	a	L	L1	t max.	D min.	Ø d h6	K10F	CN45F	AL41F	PD2F	Klemmhalter Typ	toolholder type
⋮ ↴														
R/L 050.4-10	0.1	1.5	3.5	24	10	0.3	4.0	4.0	●	●	●		645, ...	640,4
R/L 050.4-16	0.1	1.5	3.5	30	16	0.3	4.0	4.0	●	●	●			
R/L 050.4-20	0.1	1.5	3.5	34	20	0.3	4.0	4.0	●	●	●			
R/L 050.4-24	0.1	1.5	3.5	38	24	0.3	4.0	4.0	●	●	●			
R/L 050.4-28	0.1	1.5	3.5	42	28	0.3	4.0	4.0	●	●				
R/L 050.5-10	0.15	1.9	4.4	25	10	0.5	5.0	5.0	●	●	●		645, ...	650,5
R/L 050.5-15	0.15	1.9	4.4	30	15	0.5	5.0	5.0	●	●	●			
R/L 050.5-20	0.15	1.9	4.4	35	20	0.5	5.0	5.0	●	●	●			
R/L 050.5-25	0.15	1.9	4.4	40	25	0.5	5.0	5.0	●	●	●			
R/L 050.5-30	0.15	1.9	4.4	45	30	0.5	5.0	5.0	●	●	●			
R/L 050.5-35	0.15	1.9	4.4	50	35	0.5	5.0	5.0	●	●				
R/L 050.5-40	0.15	1.9	4.4	55	40	0.5	5.0	5.0	●	●				
↳ ...														

Weitere HM Sorten können Sie in der Sortenübersicht im Kapitel "Technische Hinweise" und der Preisliste finden.

Bestellbeispiel:
für rechte Ausführung und Sorte
R050.4-10/AL41F

More carbide grades you can find in the grades summary in the chapter "technical instructions" and in the price list.

order-example:
righthand version and grade
R050.4-10/AL41F