

**ULTRAMINI**

Bohrungsbearbeitung  
ab  $\varnothing$  0.2 mm

grooving, boring and profiling  
starting at  $\varnothing$  0.2 mm

**Typ 050**

Audreihen und Kopieren

D min. 0.2 - 9.8 mm

boring and profiling

D min. 0.2 - 9.8 mm

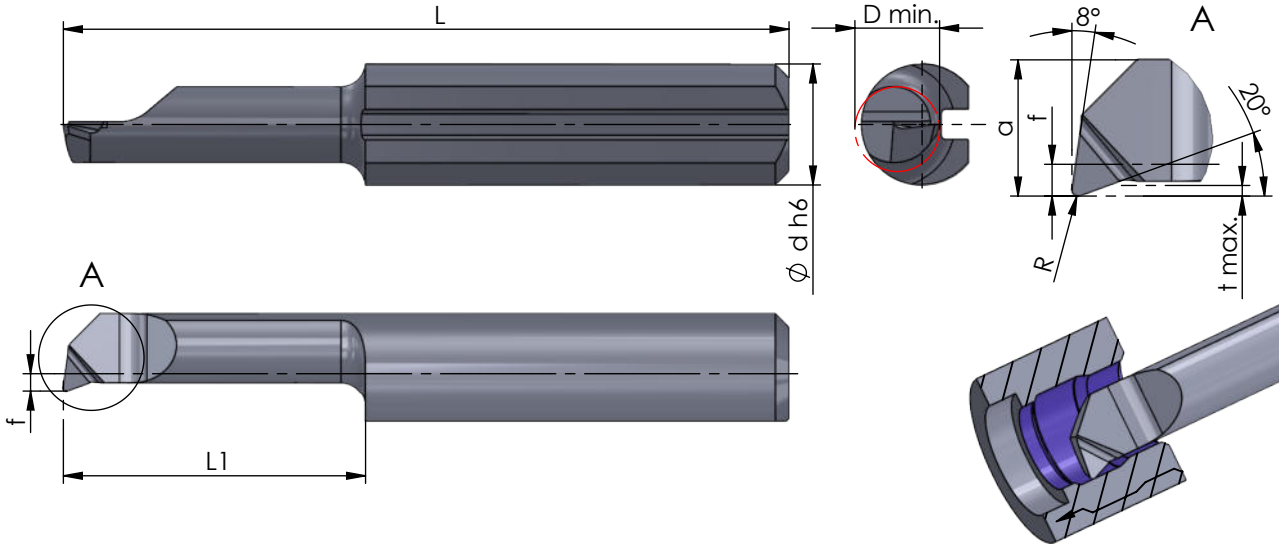

Rechts (R): wie gezeichnet  
Links (L): spiegelbildlich

righthand (R): as shown  
lefthand version (L): mirror image

Abmessungen in mm

dimensions in mm

Bestellnummer part number	R	f	a	L	L1	t max.	D min.	Ø d h6	K10F CN45F AL41F PD2F	Klemmhalter Typ toolholder type
R/L 050.6-15	0.15	2.3	5.3	30	15	0.5	6.0	6.0	● ● ●	676... 660... ...6
R/L 050.6-22	0.15	2.3	5.3	37	22	0.5	6.0	6.0	● ● ●	
R/L 050.6-25	0.15	2.3	5.3	40	25	0.5	6.0	6.0	● ● ●	
R/L 050.6-30	0.15	2.3	5.3	45	30	0.5	6.0	6.0	● ● ●	
R/L 050.6-35	0.15	2.3	5.3	50	35	0.5	6.0	6.0	● ● ●	
R/L 050.6-42	0.15	2.3	5.3	57	42	0.5	6.0	6.0	● ● ●	
R/L 050.7-20	0.15	2.8	6.3	35	20	0.6	6.8	7.0	● ● ●	676... 670... 687... ...7
R/L 050.7-25	0.15	2.8	6.3	40	25	0.6	6.8	7.0	● ● ●	
R/L 050.7-30	0.15	2.8	6.3	45	30	0.6	6.8	7.0	● ● ●	
R/L 050.7-35	0.15	2.8	6.3	50	35	0.6	6.8	7.0	● ● ●	
R/L 050.7-40	0.15	2.8	6.3	55	40	0.6	6.8	7.0	● ● ●	
R/L 050.7-45	0.15	2.8	6.3	60	45	0.6	6.8	7.0	● ● ●	
R/L 050.7-50	0.15	2.8	6.3	65	50	0.6	6.8	7.0	● ● ●	
↳ ...										

Weitere HM Sorten können Sie in der Sortenübersicht im Kapitel "Technische Hinweise" und der Preisliste finden.

Bestellbeispiel:  
für rechte Ausführung und Sorte  
R050.6-15/AL41F

More carbide grades you can find in the grades summary in the chapter "technical instructions" and in the price list.

order-example:  
righthand version and grade  
R050.6-15/AL41F