

SYSTEM 500

Nut- und Trennfräsen

groove milling
and slotting cutter

Typ 514

Fräswendeschnidplatte,
für Sicherungsringe DIN 471 / 472

indexable milling insert,
for circlip groove DIN 471 / 472

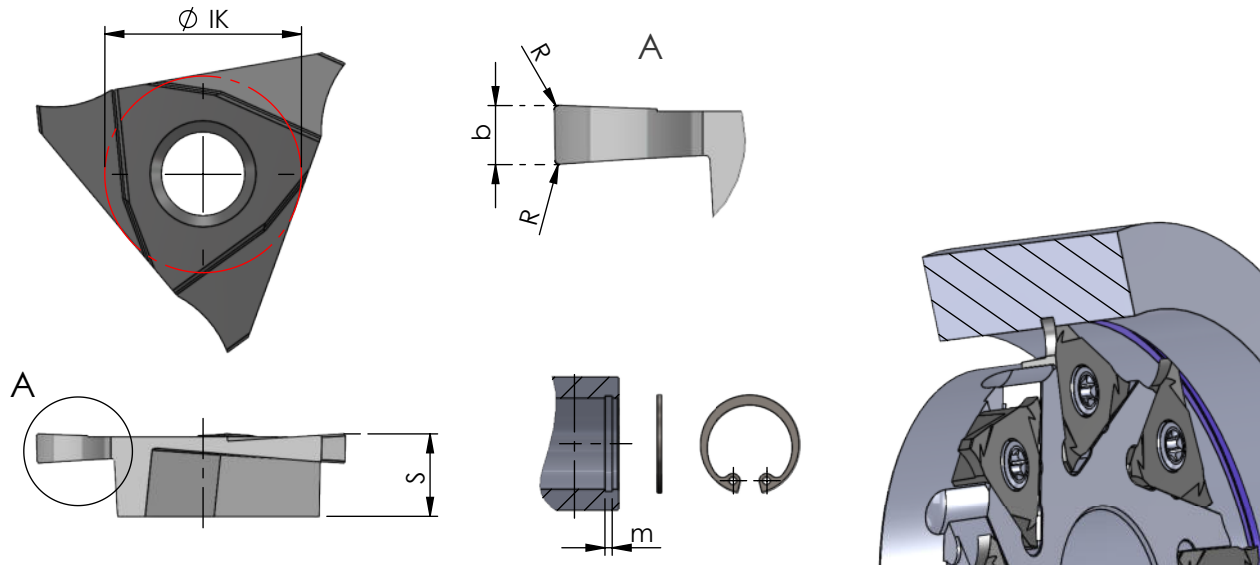

Abmessungen in mm

dimensions in mm



Bestellnummer part number	Nut-Maß m groove dim. m DIN 471 / DIN 472		S	b -0.02	R	$\varnothing IK -0.03$	K10F AL41F CN45F	für Fräseschaft / Messerkopf for milling shank / milling cutter
514.0130.00	1.3		5.4	1.41	0.1	13	● ● ●	500... 510... 581...
514.0160.00	1.6		5.4	1.71	0.15	13	● ● ●	
514.0185.00	1.85		5.4	1.96	0.15	13	● ● ●	
514.0215.00	2.15		5.4	2.26	0.15	13	● ● ●	
514.0265.00	2.65		5.4	2.76	0.15	13	● ● ●	
514.0315.00	3.15		5.4	3.26	0.15	13	● ● ●	
514.0415.00	4.15		5.4	4.26	0.15	13	● ● ●	
514.0515.00	5.15		5.4	5.26	0.15	13	● ● ●	

Weitere HM Sorten können Sie in der Sortenübersicht im Kapitel "Technische Hinweise" und der Preisliste finden.

Bestellbeispiel für Sorte AL41F:
Rechts: 514.0130.00/AL41F
Links: L514.0130.00/AL41F (auf Anfrage)

More carbide grades you can find in the grades summary in the chapter "technical instructions" and in the price list.

order-example grade AL41F:
right: 514.0130.00/AL41F
left: L514.0130.00/AL41F (on demand)