

SYSTEM 500

Nut- und Trennfräsen

groove milling
and slotting cutter

Typ 514

Fräswendeschnidplatte,
für Sicherungsringe DIN 471 / 472,
mit Nutaußenkantenfasung

indexable milling insert,
for circlip groove DIN 471 / 472,
with chamfer

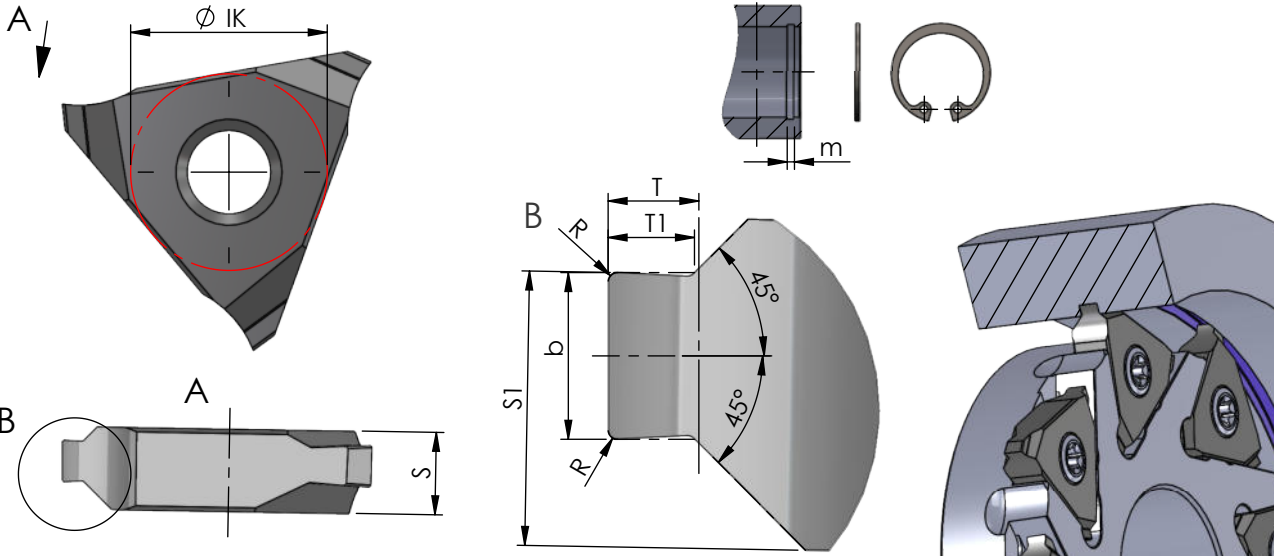

Abmessungen in mm

dimensions in mm

Bestellnummer part number	Nut-Maß m groove dim. m DIN 471 / DIN 472	S	S1 ±0.01	b -0.02	R	T1 -0.04 Formtiefe depth of form	T	Ø IK -0.03	K10F	AL41F	CN45F	für Fräseschaft / Messerkopf for milling shank / milling cutter
514.1105.35	1.1	5.4	4.52	1.21	0.1	0.49	0.50	13	●	●	●	500... 510... 581...
514.1307.35	1.3	5.4	4.62	1.41	0.1	0.67	0.70	13	●	●	●	
514.1308.35	1.3	5.4	4.62	1.41	0.1	0.83	0.85	13	●	●	●	
514.1609.35	1.6	5.4	4.52	1.71	0.15	0.83	0.85	13	●	●	●	
514.1610.35	1.6	5.4	4.52	1.71	0.15	0.97	1.00	13	●	●	●	
514.1812.35	1.85	5.4	4.64	1.96	0.15	1.23	1.25	13	●	●	●	
514.2115.43	2.15	5.4	4.79	2.26	0.15	1.47	1.50	13	●	●	●	
514.2616.43	2.65	5.4	4.54	2.76	0.15	1.47	1.50	13	●	●	●	
514.2617.43	2.65	5.4	4.54	2.76	0.15	1.72	1.75	13	●	●	●	
514.3118.53	3.15	5.4	4.79	3.26	0.15	1.72	1.75	13	●	●	●	
514.4120.53	4.15	5.4	4.99	4.26	0.15	1.97	2.00	13	●	●	●	
514.4125.53	4.15	5.4	4.99	4.26	0.15	2.47	2.50	13	●	●	●	
514.5130.61	5.15	6.1	5.85	5.26	0.15	2.97	3.00	13	●	●	●	

Weitere HM Sorten können Sie in der Sortenübersicht im Kapitel "Technische Hinweise" und der Preisliste finden.

Bestellbeispiel für Sorte AL41F:
Rechts: 514.1105.35/AL41F
Links: L514.1105.35/AL41F (auf Anfrage)

More carbide grades you can find in the grades summary in the chapter "technical instructions" and in the price list.

order-example grade AL41F:
right: 514.1105.35/AL41F
left: L514.1105.35/AL41F (on demand)