

SYSTEM 500

Nut- und Trennfräsen

groove milling
and slotting cutter

Typ 591... .3

Hochleistungs Aufsteck-Trennfräser
mit Bohrung und
Quernut nach DIN 138

high performance arbour mounted
slotting cutter with bore and cross
keyway according DIN 138

Nutbreite $b = 3$ mm
Nuttiefe t max. 44 mm
Schneidkreis- \emptyset DS ab 63 mm

width of groove $b = 3$ mm
depth of groove t max. 44 mm
cutting edge- \emptyset DS starting at 63 mm

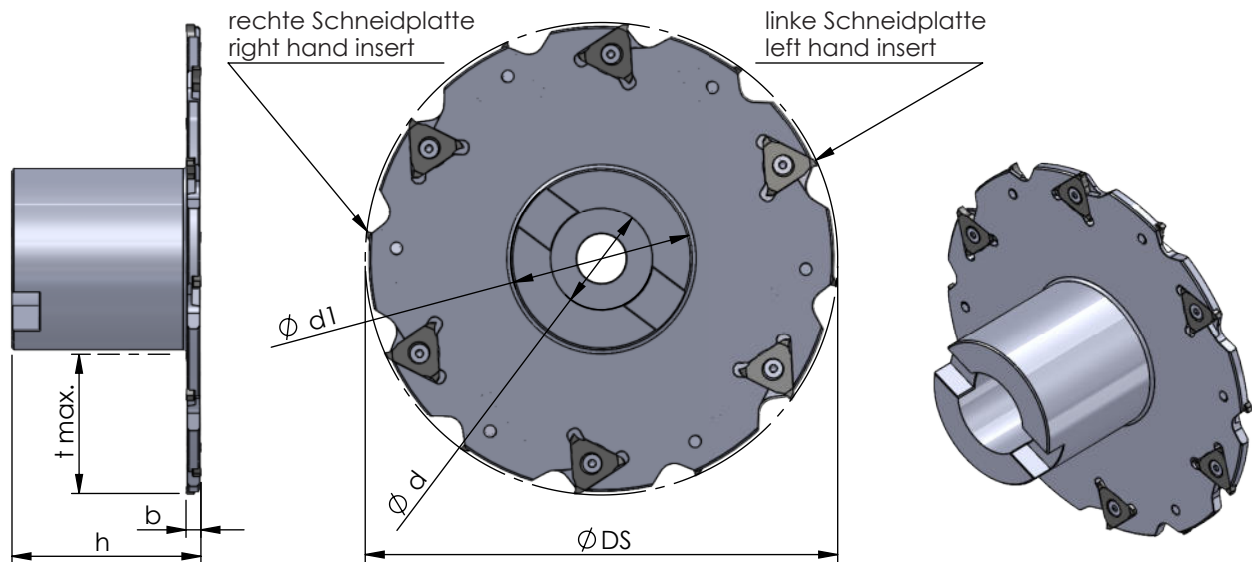

weitere Abmessungen auf
Anfrage

further sizes upon request

Abmessungen in mm

dimensions in mm



Bestellnummer part number	Ø DS	Ø d	b	Ø d1	h	t max.	Spannschraube screw	Schraubenschlüssel wrench	Anzugs- drehmoment torque	Befestigung/fixing		Anzahl Schneidplatten R/L number inserts R/L	Schneidplatte insert type
										Spannschraube screw	Unterleg- scheibe washer		
591.0063.16.3	63	16	3	27	50	17.5	025.03F	DSD- TX7/07	0.7 Nm	DIN 912-	DIN125-	4/4	R/L 510.0317
591.0080.16.3	80	16	3	28	50	25				M8 x 40	8.4/5	4/4	
591.0100.27.3	100	27	3	48	50	25				DIN 912-	DIN433-	5/5	
591.0125.27.3	125	27	3	48	50	37.5				M12 x 35	13-2	6/6	
591.0160.40.3	160	40	3	70	50	44				M20 x 40	21-3	8/8	

Achtung:
Trennfräser ist ohne Schneidplatten!

attention:
slotting cutter is without inserts!

Bestellbeispiel:
591.0063.16.3

order-example:
591.0063.16.3