

ULTRAMINI

Bohrungsbearbeitung
ab $\varnothing 0.2 \text{ mm}$

grooving, boring and profiling
starting at $\varnothing 0.2 \text{ mm}$

Typ 055

Ausdrehen und Kopieren
mit Eckenradius 0.05 mm

boring and profiling
with corner radius 0.05 mm

D min. 2.0 - 6.0 mm

D min. 2.0 - 6.0 mm

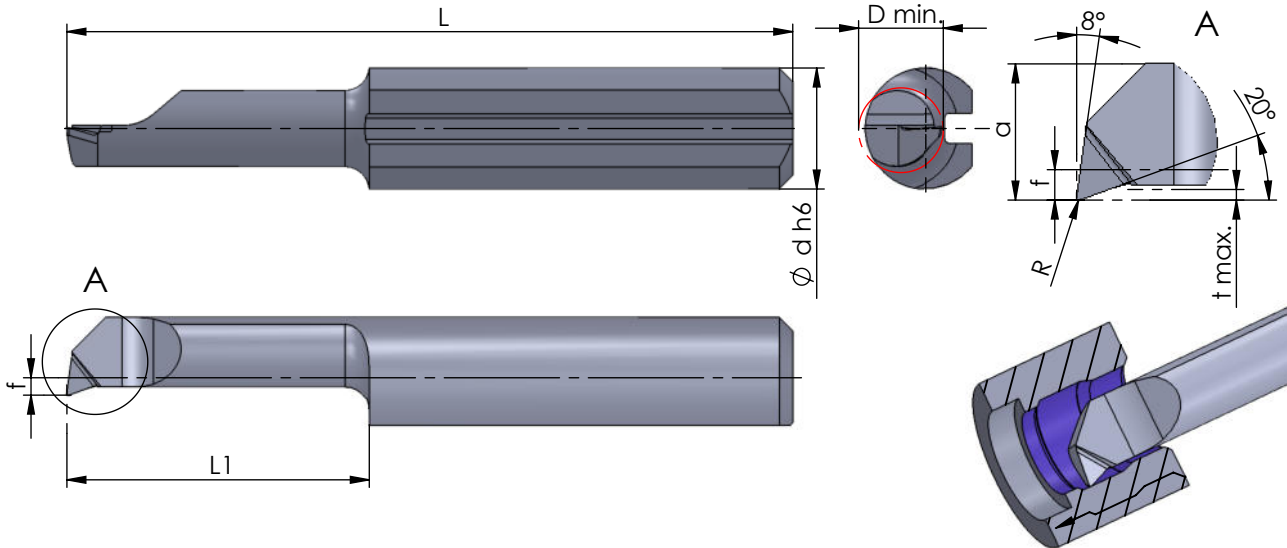

Rechts (R): wie gezeichnet
Links (L): spiegelbildlich

righthand (R): as shown
lefthand version (L): mirror image

Abmessungen in mm

dimensions in mm

Bestellnummer part number	R	f	a	L	L1	t max.	D min.	Ø d h6					Klemmhalter Typ toolholder type
									K10F	CN45F	AL41F	PD2F	
R/L 055.2-5	0.05		1.7	19	5	0.1	2.0	4.0			●		640... 645... ...4
R/L 055.2-10	0.05		1.7	24	10	0.1	2.0	4.0			●		
R/L 055.2-15	0.05		1.7	29	15	0.1	2.0	4.0			●		
R/L 055.3-10	0.05	0.6	2.6	24	10	0.2	2.8	4.0			●		
R/L 055.3-16	0.05	0.6	2.6	30	16	0.2	2.8	4.0			●		
R/L 055.3-20	0.05	0.6	2.6	34	20	0.2	2.8	4.0			●		
R/L 055.4-10	0.05	1.5	3.5	24	10	0.3	4.0	4.0			●		
R/L 055.4-16	0.05	1.5	3.5	30	16	0.3	4.0	4.0			●		
R/L 055.4-20	0.05	1.5	3.5	34	20	0.3	4.0	4.0			●		
R/L 055.4-24	0.05	1.5	3.5	38	24	0.3	4.0	4.0			●		
R/L 055.4-28	0.05	1.5	3.5	42	28	0.3	4.0	4.0			●		
↳ ...													

Weitere HM Sorten können Sie in der Sortenübersicht im Kapitel "Technische Hinweise" und der Preisliste finden.

Bestellbeispiel:
für rechte Ausführung und Sorte
R055.2-5/AL41F

More carbide grades you can find in the grades summary in the chapter "technical instructions" and in the price list.

order-example:
righthand version and grade
R055.2-5/AL41F