

ULTRAMINI

Bohrungsbearbeitung
ab $\varnothing 0.2$ mm

grooving, boring and profiling
starting at $\varnothing 0.2$ mm

Mediline Typ M050

Audreihen und Kopieren
mit innerer Kühlmittelzufuhr
und modifizierter Geometrie

boring and profiling
with through coolant
and modified profile

D min. 0.5 - 4.0 mm

D min. 0.5 - 4.0 mm

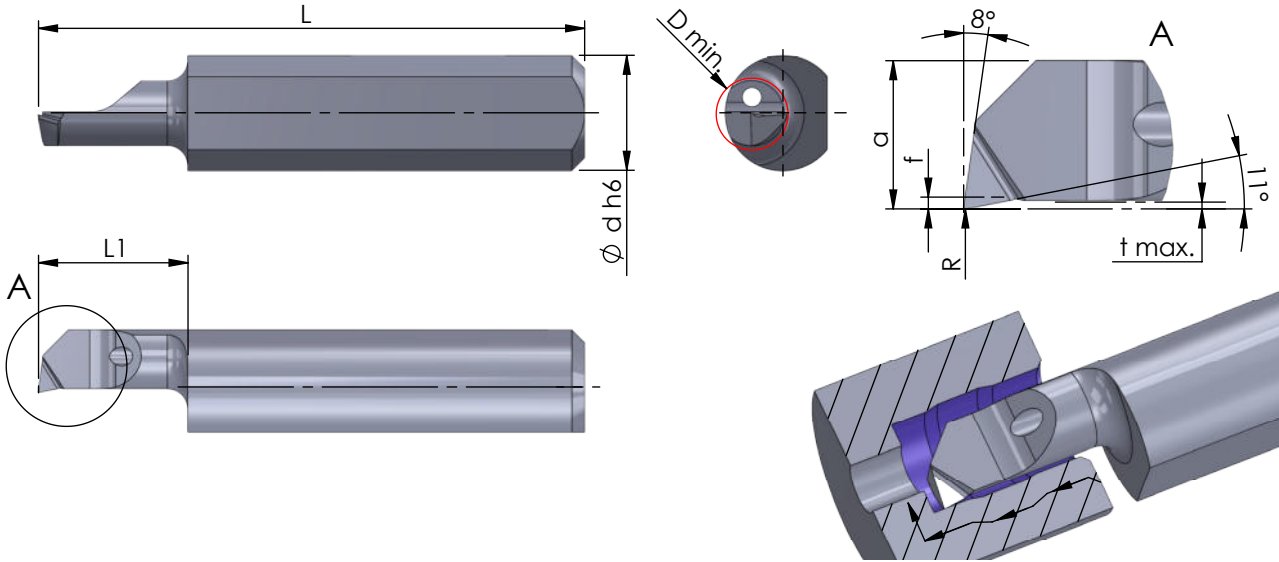

Rechts (R): wie gezeichnet
Links (L): spiegelbildlich

righthand (R): as shown
lefthand version (L): mirror image

Abmessungen in mm

dimensions in mm

Bestellnummer part number														Klemmhalter Typ toolholder type
	R	f	a	L	L1	t max.	D min.	Ø d h6	K10F	CN45F	AL41F	P07C		
...														
R/L M050.25-5	0.02	0.2	2.2	19	5	0.1	2.5	4.0	●			●	640... 645... ...4	
R/L M050.25-10	0.02	0.2	2.2	24	10	0.1	2.5	4.0	●			●		
R/L M050.3-10	0.02	0.6	2.6	24	10	0.15	3	4.0	●			●		
R/L M050.3-16	0.02	0.6	2.6	30	16	0.15	3	4.0	●			●		
R/L M050.35-10	0.02	1.1	3.1	24	10	0.17	3.5	4.0	●			●		
R/L M050.35-16	0.02	1.1	3.1	30	16	0.17	3.5	4.0	●			●		
R/L M050.35-20	0.02	1.1	3.1	34	20	0.17	3.5	4.0	●			●		
R/L M050.4-10	0.02	1.5	3.5	24	10	0.2	4	4.0	●			●		
R/L M050.4-16	0.02	1.5	3.5	30	16	0.2	4	4.0	●			●		
R/L M050.4-20	0.02	1.5	3.5	34	20	0.2	4	4.0	●			●		
R/L M050.4-24	0.02	1.5	3.5	38	24	0.2	4	4.0	●			●		

Weitere HM Sorten können Sie in der Sortenübersicht im Kapitel "Technische Hinweise" und der Preisliste finden.

Bestellbeispiel:
für rechte Ausführung und Sorte
RM050.25-5/P07C

weitere Informationen:
• siehe Allgemeine Beschreibung

more informations:
• look at the general instructions

More carbide grades you can find in the grades summary in the chapter "technical instructions" and in the price list.

order-example:
righthand version and grade
RM050.25-5/P07C