

ULTRAMINI

Bohrungsbearbeitung
ab $\varnothing 0.2$ mm

grooving, boring and profiling
starting at $\varnothing 0.2$ mm

Xtraline Typ X050

Audreihen und Kopieren
mit innerer Kühlmittelzufuhr,
Spantreppe, extra stabile Ausführung

boring and profiling
with through coolant,
chipbreaker
and extra solid construction

D min. 1.0 - 7.0 mm

D min. 1.0 - 7.0 mm

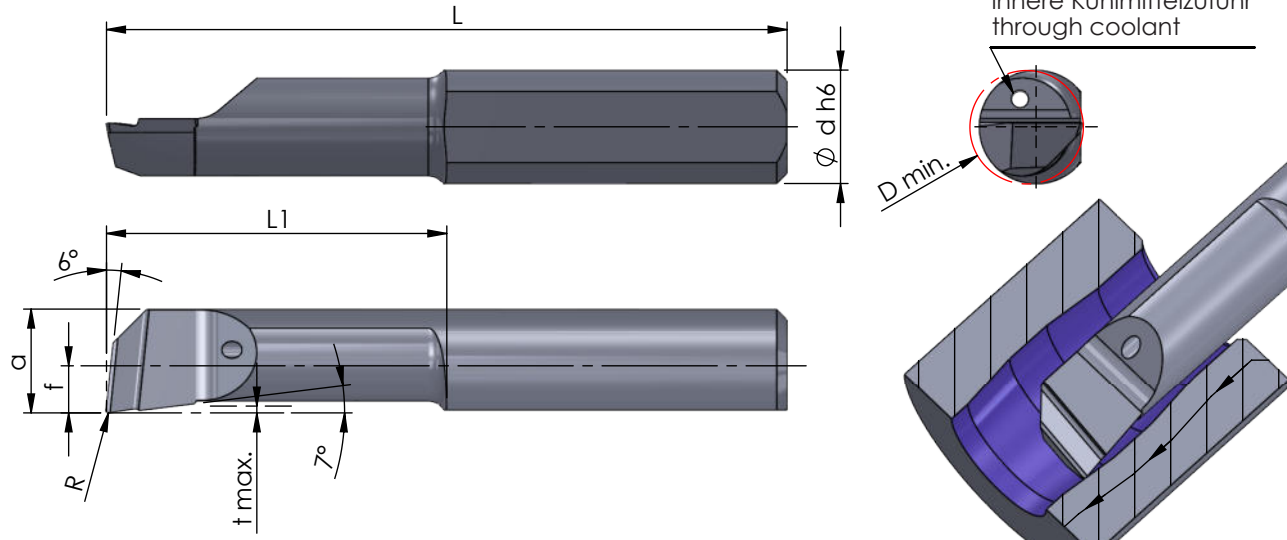

Rechts (R): wie gezeichnet
Links (L): spiegelbildlich

righthand (R): as shown
lefthand version (L): mirror image

Abmessungen in mm

dimensions in mm

Bestellnummer part number	R	f	a	L	L1	t max.	D min.	$\varnothing d h6$	Klemmhalter Typ toolholder type				
									K10F	CN45F	AL41F	P18C	
R/L X050.4-10R10	0.1	1.6	3.6	24	10	0.2	4.0	4.0	●		●		
R/L X050.4-10R20	0.2	1.6	3.6	24	10	0.2	4.0	4.0	●		●		
R/L X050.4-16R05	0.05	1.6	3.6	30	16	0.2	4.0	4.0	●		●		
R/L X050.4-16R10	0.1	1.6	3.6	30	16	0.2	4.0	4.0	●		●		
R/L X050.4-16R20	0.2	1.6	3.6	30	16	0.2	4.0	4.0	●		●		640... 645... ...4
R/L X050.4-16R40	0.4	1.6	3.6	30	16	0.2	4.0	4.0			●		
R/L X050.4-24R10	0.1	1.6	3.6	38	24	0.2	4.0	4.0	●		●		
R/L X050.4-24R20	0.2	1.6	3.6	38	24	0.2	4.0	4.0	●		●		
R/L X050.4-24R40	0.4	1.6	3.6	38	24	0.2	4.0	4.0			●		

Weitere HM Sorten können Sie in der Sortenübersicht im Kapitel "Technische Hinweise" und der Preisliste finden.

Bestellbeispiel:
für rechte Ausführung und Sorte
RX050.4-10R10/P18C

weitere Informationen:
• **siehe Allgemeine Beschreibung**

more informations:
• **look at the general instructions**

More carbide grades you can find in the grades summary in the chapter "technical instructions" and in the price list.

order-example:
righthand version and grade
RX050.4-10R10/P18C