

ULTRAMINI

Bohrungsbearbeitung
ab $\varnothing 0.2$ mm

grooving, boring and profiling
starting at $\varnothing 0.2$ mm

Xtraline Typ X050

Ausdrehen und Kopieren
mit innerer Kühlmittelzufuhr,
Spantreppe, extra stabile Ausführung

D min. 1.0 - 7.0 mm

boring and profiling
with through coolant,
chipbreaker and extra solid construction

D min. 1.0 - 7.0 mm

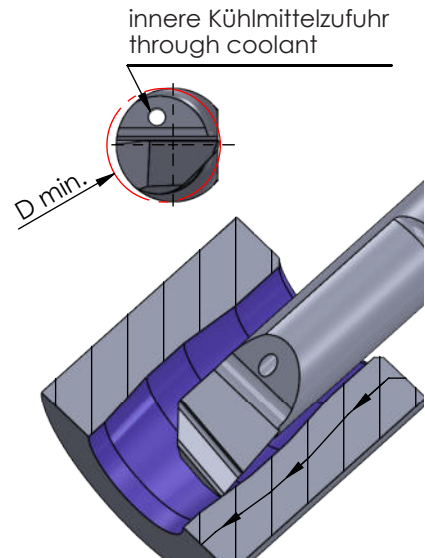
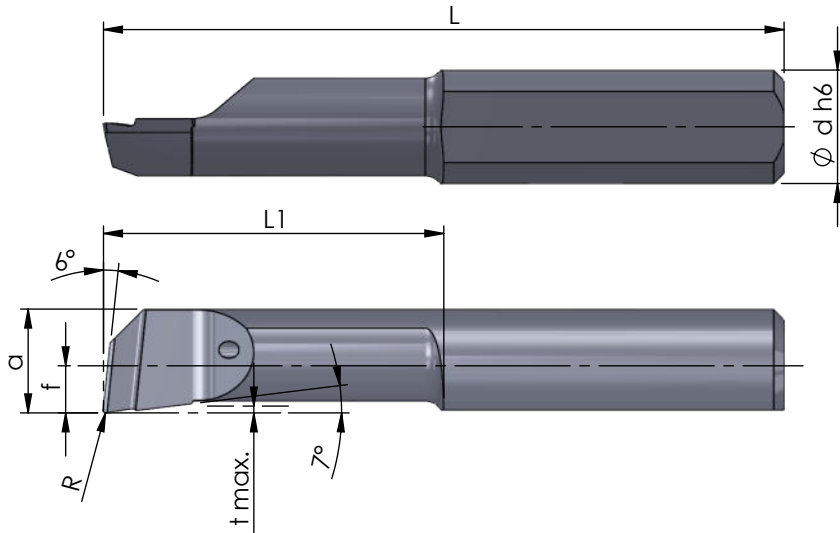

Rechts (R): wie gezeichnet
Links (L): spiegelbildlich

righthand (R): as shown
lefthand version (L): mirror image

Abmessungen in mm

dimensions in mm

Bestellnummer part number	R	f	a	L	L1	t max.	D min.	$\varnothing d h6$	Klemmhalter Typ toolholder type					
									K10F	CN45F	AL41F	P18C		
...														
R/L X050.5-15R05	0.05	2.1	4.6	30	15	0.3	5.0	5.0	●		●			
R/L X050.5-15R10	0.1	2.1	4.6	30	15	0.3	5.0	5.0	●		●			
R/L X050.5-15R20	0.2	2.1	4.6	30	15	0.3	5.0	5.0	●		●			
R/L X050.5-15R40	0.4	2.1	4.6	30	15	0.3	5.0	5.0			●			
R/L X050.5-25R10	0.1	2.1	4.6	40	25	0.3	5.0	5.0	●		●			
R/L X050.5-25R20	0.2	2.1	4.6	40	25	0.3	5.0	5.0	●		●			
R/L X050.5-30R10	0.1	2.1	4.6	45	30	0.3	5.0	5.0	●		●			
R/L X050.5-30R20	0.2	2.1	4.6	45	30	0.3	5.0	5.0	●		●			
R/L X050.5-30R40	0.4	2.1	4.6	45	30	0.3	5.0	5.0			●			
...														

Weitere HM Sorten können Sie in der Sortenübersicht im Kapitel "Technische Hinweise" und der Preisliste finden.

Bestellbeispiel:
für rechte Ausführung und Sorte
RX050.5-15R05/P18C

weitere Informationen:

- siehe Allgemeine Beschreibung

more informations:

- look at the general instructions

More carbide grades you can find in the grades summary in the chapter "technical instructions" and in the price list.

order-example:
righthand version and grade
RX050.5-15R05/P18C