

**ULTRAMINI**

Bohrungsbearbeitung  
ab Ø 0.2 mm

grooving, boring and profiling  
starting at Ø 0.2 mm

**Typ 080**

Rückwärtsdrehen

D min. 3.0 - 7.0 mm

backboring

D min. 3.0 - 7.0 mm

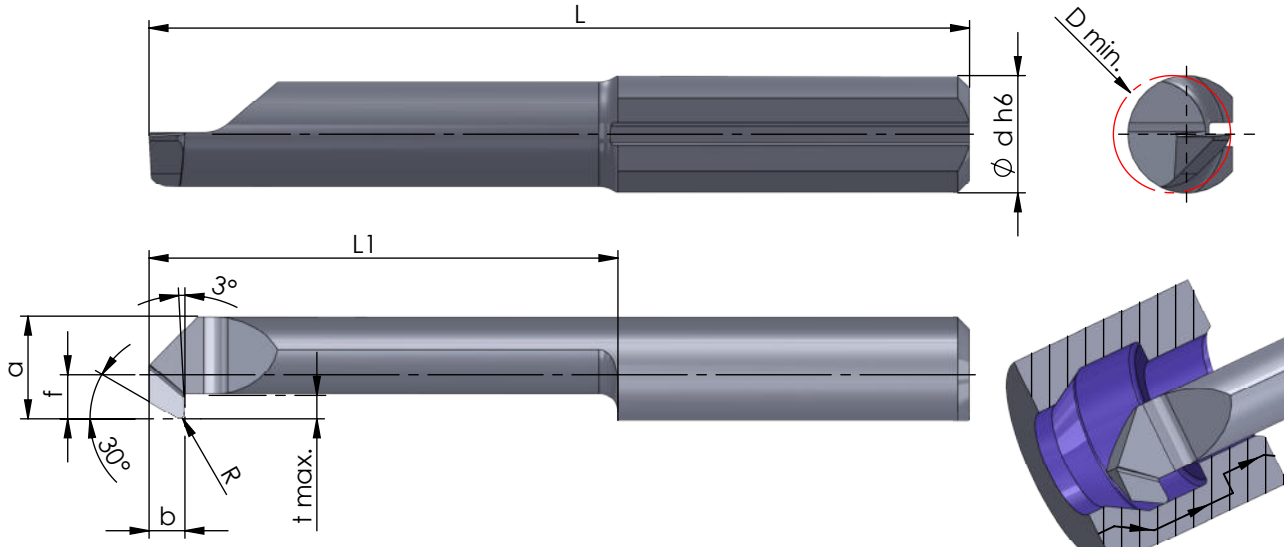

Rechts (R): wie gezeichnet  
Links (L): spiegelbildlich

righthand (R): as shown  
lefthand version (L): mirror image

Abmessungen in mm

dimensions in mm

Bestellnummer part number	b	R	f	a	L	L1	t max.	D min.	Ø d h6					Klemhalter Typ toolholder type	
										K10F	CN45F	AL41F	PD2F		
R/L 080.0003-15	1.5	0.1	0.6	2.6	30	15	0.5	3.0	4.0	●					
R/L 080.0003-20	1.5	0.1	0.6	2.6	34	20	0.5	3.0	4.0	●					
R/L 080.0004-15	1.5	0.15	1.5	3.5	30	15	0.8	4.0	4.0	●					
R/L 080.0004-25	1.5	0.15	1.5	3.5	39	25	0.8	4.0	4.0	●					
R/L 080.0005-20	1.5	0.2	1.9	4.4	35	20	1.0	5.0	5.0	●					
R/L 080.0005-30	1.5	0.2	1.9	4.4	45	30	1.0	5.0	5.0	●					
R/L 080.0006-20	1.5	0.2	2.3	5.3	35	20	1.8	6.0	6.0	●					
R/L 080.0006-30	1.5	0.2	2.3	5.3	45	30	1.8	6.0	6.0	●					
R/L 080.0007-20	1.5	0.2	2.8	6.3	35	20	2.5	7.0	7.0	●					
R/L 080.0007-30	1.5	0.2	2.8	6.3	45	30	2.5	7.0	7.0	●					

Weitere HM Sorten können Sie in der Sortenübersicht im Kapitel "Technische Hinweise" und der Preisliste finden.

Bestellbeispiel:  
für rechte Ausführung und Sorte  
R080.0003-15/CN45F

More carbide grades you can find in the grades summary in the chapter "technical instructions" and in the price list.

order-example:  
righthand version and grade  
R080.0003-15/CN45F