

ULTRAMINI

Bohrungsbearbeitung
ab $\varnothing 0.2$ mm

grooving, boring and profiling
starting at $\varnothing 0.2$ mm

Typ 001 / 0015

Stechdrehen

grooving

D min. 1.0 / 1.5 mm
Stechtiefe t max. 0.2 / 0.4 mm

D min. 1.0 / 1.5 mm
depth of groove t max. 0.2 / 0.4 mm

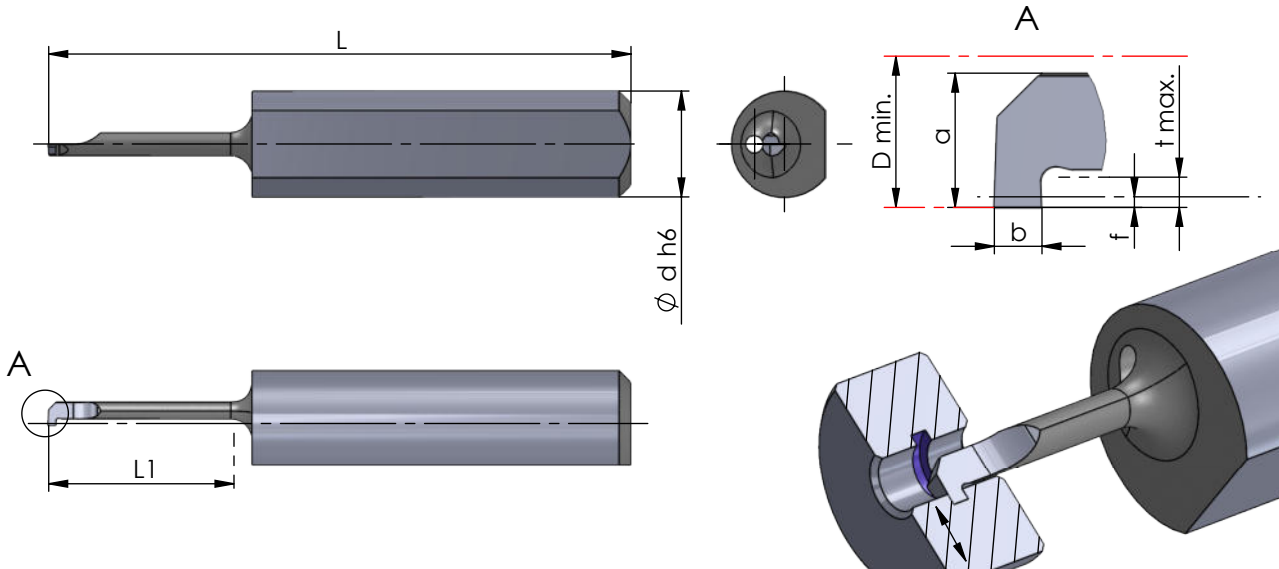

Rechts (R): wie gezeichnet
Links (L): spiegelbildlich

righthand (R): as shown
lefthand version (L): mirror image

Abmessungen in mm

dimensions in mm

Bestellnummer part number	b +0.03	a	f	L	L1	t max.	D min.	Ø d h6	Klemmhalter Typ toolholder type				
									K10F	CN45F	AL41F	P07C	
R/L 001.0030-4	0.3	0.9	0.1	20	4	0.2	1.0	4.0			●		
R/L 001.0030-7	0.3	0.9	0.1	22	7	0.2	1.0	4.0			●		
R/L 0015.0040-5	0.4	1.4	0.55	22	5	0.4	1.5	4.0			●		640... 645... ...4
R/L 0015.0040-10	0.4	1.4	0.55	25	10	0.4	1.5	4.0			●		
R/L 0015.0040-12	0.4	1.4	0.55	27	12	0.4	1.5	4.0			●		

Weitere HM Sorten können Sie in der Sortenübersicht im Kapitel "Technische Hinweise" und der Preisliste finden.

Bestellbeispiel:
für rechte Ausführung und Sorte
R001.0030-4/AL41F

More carbide grades you can find in the grades summary in the chapter "technical instructions" and in the price list.

order-example:
righthand version and grade
R001.0030-4/AL41F