

# ULTRAMINI

Bohrungsbearbeitung  
ab  $\varnothing 0.2 \text{ mm}$

grooving, boring and profiling  
starting at  $\varnothing 0.2 \text{ mm}$

# Typ 005

Stechdrehen

grooving

D min. 5.0 mm  
Stechtiefe t max. 1.0 mm  
Auskrägung (L1) bis 7x D

D min. 5.0 mm  
depth of groove t max. 1.0 mm  
overhang length (L1) up to 7x D

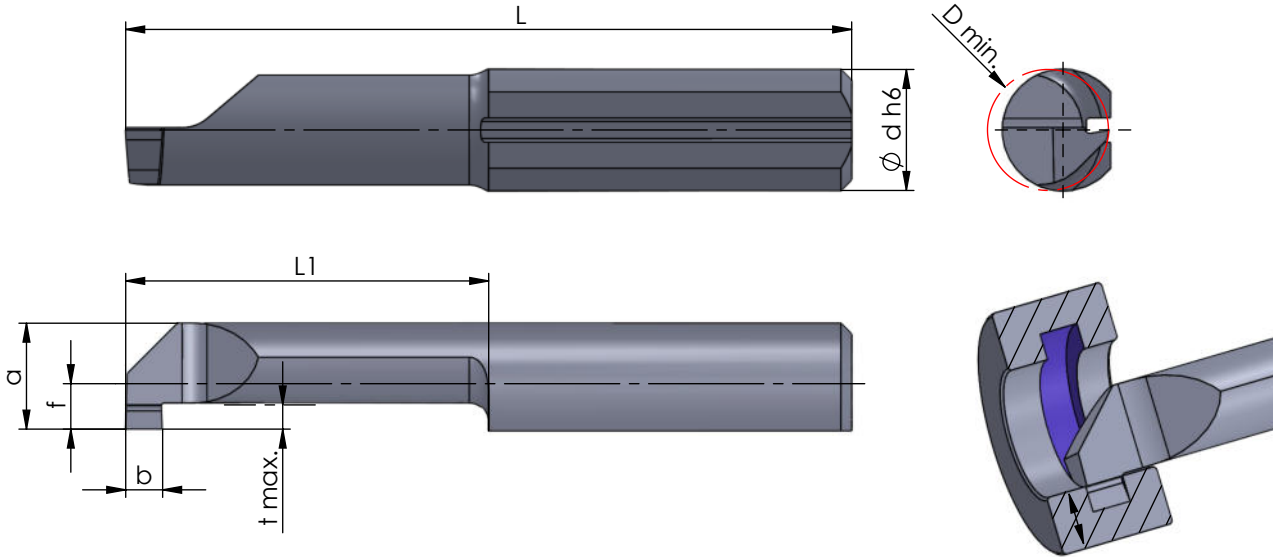

Rechts (R): wie gezeichnet  
Links (L): spiegelbildlich

righthand (R): as shown  
lefthand version (L): mirror image

Abmessungen in mm

dimensions in mm

Bestellnummer part number	b +0.05		f	a	L	L1	t max.	D min.	Ø d h6	K10F CN45F AL41F P07C	Klemmhalter Typ toolholder type
	b	b (inch)									
R/L 005.0100-10	1.0		1.9	4.4	25	10	1.0	5.0	5.0	● ●	645... 650... ...5
R/L 005.0100-15	1.0		1.9	4.4	30	15	1.0	5.0	5.0	● ●	
R/L 005.0100-20	1.0		1.9	4.4	35	20	1.0	5.0	5.0	● ●	
R/L 005.0100-25	1.0		1.9	4.4	40	25	1.0	5.0	5.0	● ●	
R/L 005.0100-30	1.0		1.9	4.4	45	30	1.0	5.0	5.0	● ●	
R/L 005.0100-35	1.0		1.9	4.4	50	35	1.0	5.0	5.0	●	
R/L 005.0117-30	1.17	0.046"	1.9	4.4	45	30	1.0	5.0	5.0	●	
R/L 005.0150-10	1.5		1.9	4.4	25	10	1.0	5.0	5.0	● ●	
R/L 005.0150-15	1.5		1.9	4.4	30	15	1.0	5.0	5.0	● ●	
R/L 005.0150-20	1.5		1.9	4.4	35	20	1.0	5.0	5.0	● ●	
R/L 005.0150-25	1.5		1.9	4.4	40	25	1.0	5.0	5.0	● ●	
R/L 005.0150-30	1.5		1.9	4.4	45	30	1.0	5.0	5.0	● ●	
↳ ...											

Weitere HM Sorten können Sie in der Sortenübersicht im Kapitel "Technische Hinweise" und der Preisliste finden.

Bestellbeispiel:  
für rechte Ausführung und Sorte  
R005.0100-10/CN45F

More carbide grades you can find in the grades summary in the chapter "technical instructions" and in the price list.

order-example:  
righthand version and grade  
R005.0100-10/CN45F