

ULTRAMINI

Bohrungsbearbeitung
ab $\varnothing 0.2$ mm

grooving, boring and profiling
starting at $\varnothing 0.2$ mm

Typ 005

Stechdrehen

grooving

D min. 5.0 mm
Stechtiefe t max. 1.0 mm
Auskrägung (L1) bis 7x D

D min. 5.0 mm
depth of groove t max. 1.0 mm
overhang length (L1) up to 7x D

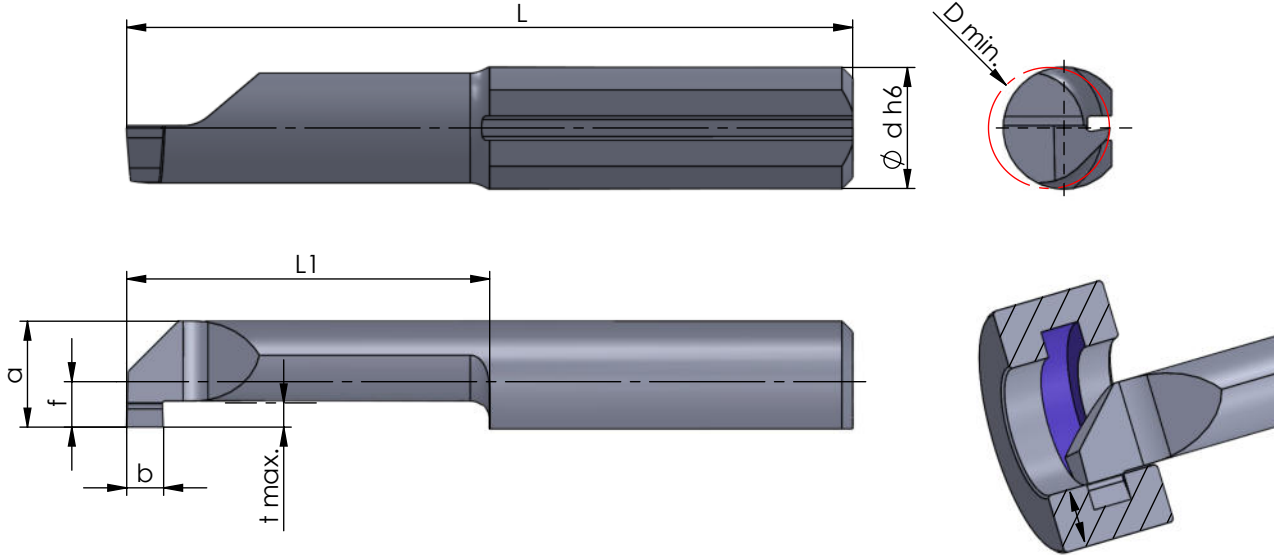

Rechts (R): wie gezeichnet
Links (L): spiegelbildlich

righthand (R): as shown
lefthand version (L): mirror image

Abmessungen in mm

dimensions in mm

Bestellnummer part number	b +0.05	b (inch)	f	a	L	L1	t max.	D min.	\varnothing d h6	Klemmhalter Typ toolholder type					
										K10F	CN45F	AL41F	P07C		
⋮ ↘															
R/L 005.0200-10	2.0	1.9	4.4	25	10	1.0	5.0	5.0	●	●					
R/L 005.0200-15	2.0	1.9	4.4	30	15	1.0	5.0	5.0	●	●					
R/L 005.0200-20	2.0	1.9	4.4	35	20	1.0	5.0	5.0	●	●					
R/L 005.0200-25	2.0	1.9	4.4	40	25	1.0	5.0	5.0	●	●					
R/L 005.0200-30	2.0	1.9	4.4	45	30	1.0	5.0	5.0	●	●					

Weitere HM Sorten können Sie in der Sortenübersicht im Kapitel "Technische Hinweise" und der Preisliste finden.

More carbide grades you can find in the grades summary in the chapter "technical instructions" and in the price list.

Bestellbeispiel:
für rechte Ausführung und Sorte
R005.0200-10/CN45F

order-example:
righthand version and grade
R005.0200-10/CN45F