

ULTRAMINI

Bohrungsbearbeitung
ab \varnothing 0.2 mm

grooving, boring and profiling
starting at \varnothing 0.2 mm

Typ 005M

Stechdrehen
mit Eckenradius

grooving
with corner radius

D min. 5.0 mm
Stechtiefe t max. 1.0 mm

D min. 5.0 mm
depth of groove t max. 1.0 mm

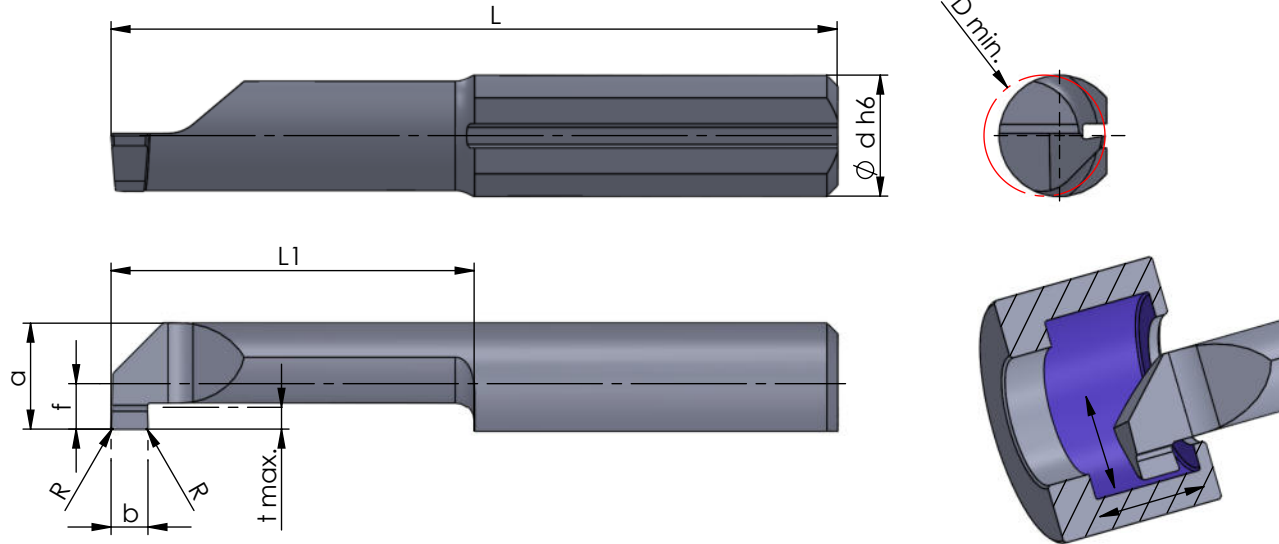

Rechts (R): wie gezeichnet
Links (L): spiegelbildlich

righthand (R): as shown
lefthand version (L): mirror image

Abmessungen in mm

dimensions in mm

Bestellnummer part number	b +0.05	b (inch)	R	f	a	L	L1	t max.	D min.	\varnothing d h6	Klemmhalter Typ				Klemmhalter Typ toolholder type
											K10F	CN45F	AL41F	P07C	
...															
R/L 005M0200-10	2.0		0.1	1.9	4.4	25	10	1.0	5.0	5.0		●			
R/L 005M0200-15	2.0		0.1	1.9	4.4	30	15	1.0	5.0	5.0		●			
R/L 005M0200-20	2.0		0.1	1.9	4.4	35	20	1.0	5.0	5.0		●			645... 650... ...5
R/L 005M0200-25	2.0		0.1	1.9	4.4	40	25	1.0	5.0	5.0		●			
R/L 005M0200-30	2.0		0.1	1.9	4.4	45	30	1.0	5.0	5.0		●			

Weitere HM Sorten können Sie in der Sortenübersicht im Kapitel "Technische Hinweise" und der Preisliste finden.

More carbide grades you can find in the grades summary in the chapter "technical instructions" and in the price list.

Bestellbeispiel:
für rechte Ausführung und Sorte
R005M0200-10/AL41F

order-example:
righthand version and grade
R005M0200-10/AL41F