

ULTRAMINI

Bohrungsbearbeitung
ab $\varnothing 0.2$ mm

grooving, boring and profiling
starting at $\varnothing 0.2$ mm

Typ 006

Stechdrehen

grooving

D min. 6.0 mm
Stechtiefe t max. 1.8 mm
Auskrägung (L1) bis 7x D

D min. 6.0 mm
depth of groove t max. 1.8 mm
overhang length (L1) up to 7x D

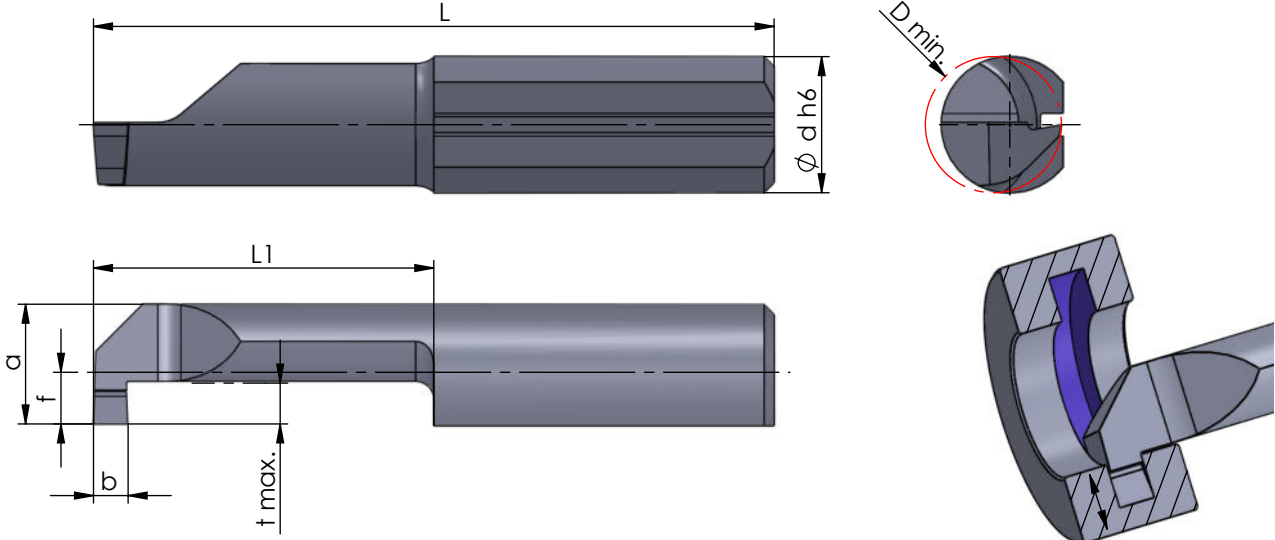

Rechts (R): wie gezeichnet
Links (L): spiegelbildlich

righthand (R): as shown
lefthand version (L): mirror image

Abmessungen in mm

dimensions in mm

Bestellnummer part number	b +0.05	f	a	L	L1	t max.	D min.	\varnothing d h6	Klemmhalter Typ				Klemmhalter Typ toolholder type
									K10F	CN45F	AL41F	P07C	
...													
R/L 006.0200-10	2.0	2.3	5.3	25	10	1.8	6.0	6.0	●	●			
R/L 006.0200-15	2.0	2.3	5.3	30	15	1.8	6.0	6.0	●	●	●		
R/L 006.0200-22	2.0	2.3	5.3	37	22	1.8	6.0	6.0	●	●			
R/L 006.0200-25	2.0	2.3	5.3	40	25	1.8	6.0	6.0	●	●			
R/L 006.0200-30	2.0	2.3	5.3	45	30	1.8	6.0	6.0	●	●			

Weitere HM Sorten können Sie in der Sortenübersicht im Kapitel "Technische Hinweise" und der Preisliste finden.

Bestellbeispiel:
für rechte Ausführung und Sorte
R006.0200-10/CN45F

More carbide grades you can find in the grades summary in the chapter "technical instructions" and in the price list.

order-example:
righthand version and grade
R006.0200-10/CN45F