

## ULTRAMINI

Bohrungsbearbeitung  
ab  $\varnothing 0.2$  mm

grooving, boring and profiling  
starting at  $\varnothing 0.2$  mm

## Typ 006M

Stechdrehen  
mit Eckenradius

grooving  
with corner radius

D min. 6.0 mm  
Stechtiefe t max. 1.8 mm

D min. 6.0 mm  
depth of groove t max. 1.8 mm

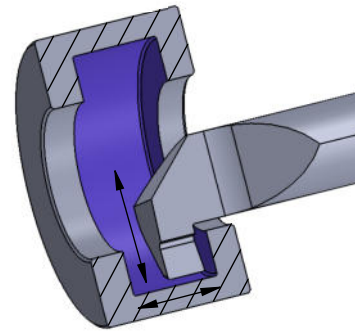
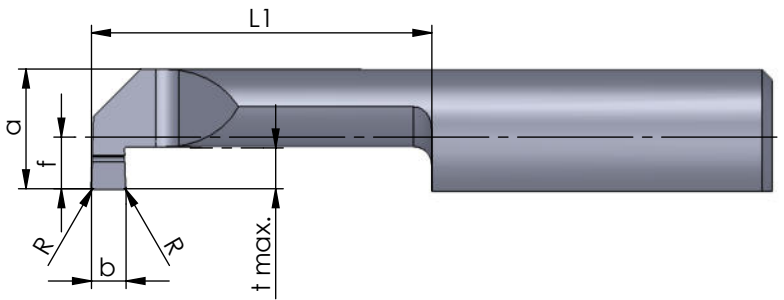
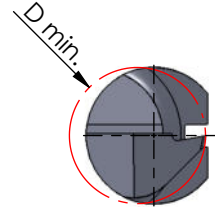
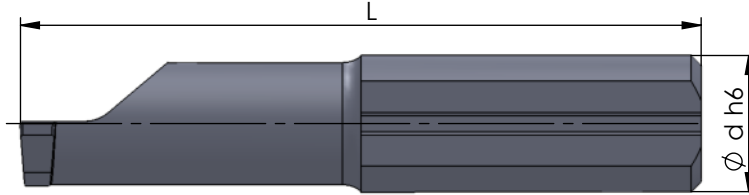

Rechts (R): wie gezeichnet  
Links (L): spiegelbildlich

righthand (R): as shown  
lefthand version (L): mirror image

Abmessungen in mm

dimensions in mm

Bestellnummer part number	b +0.05	b (inch)	R	f	a	L	L1	t max.	D min.	Ø d h6	Klemmhalter Typ				Klemmhalter Typ toolholder type
											K10F	CN45F	AL41F	PD2F	
...															
R/L 006M0198-15	1.98	0.078"	0.1	2.3	5.3	30	15	1.8	6.0	6.0		●			
R/L 006M0200-10	2.0		0.1	2.3	5.3	25	10	1.8	6.0	6.0		●			
R/L 006M0200-15	2.0		0.1	2.3	5.3	30	15	1.8	6.0	6.0		●			
R/L 006M0200-22	2.0		0.1	2.3	5.3	37	22	1.8	6.0	6.0		●			660... 676... ...:6
R/L 006M0200-25	2.0		0.1	2.3	5.3	40	25	1.8	6.0	6.0		●			
R/L 006M0200-30	2.0		0.1	2.3	5.3	45	30	1.8	6.0	6.0		●			

Weitere HM Sorten können Sie in der Sortenübersicht im Kapitel "Technische Hinweise" und der Preisliste finden.

Bestellbeispiel:  
für rechte Ausführung und Sorte  
R006M0198-15/AL41F

More carbide grades you can find in the grades summary in the chapter "technical instructions" and in the price list.

order-example:  
righthand version and grade  
R006M0198-15/AL41F