

ULTRAMINI

Bohrungsbearbeitung
ab \varnothing 0.2 mm

grooving, boring and profiling
starting at \varnothing 0.2 mm

Typ 007

Stechdrehen

grooving

D min. 6.8 mm
Stechtiefe t max. 2.5 mm
Auskragung (L1) bis 7x D

D min. 6.8 mm
depth of groove t max. 2.5 mm
overhang length (L1) up to 7x D

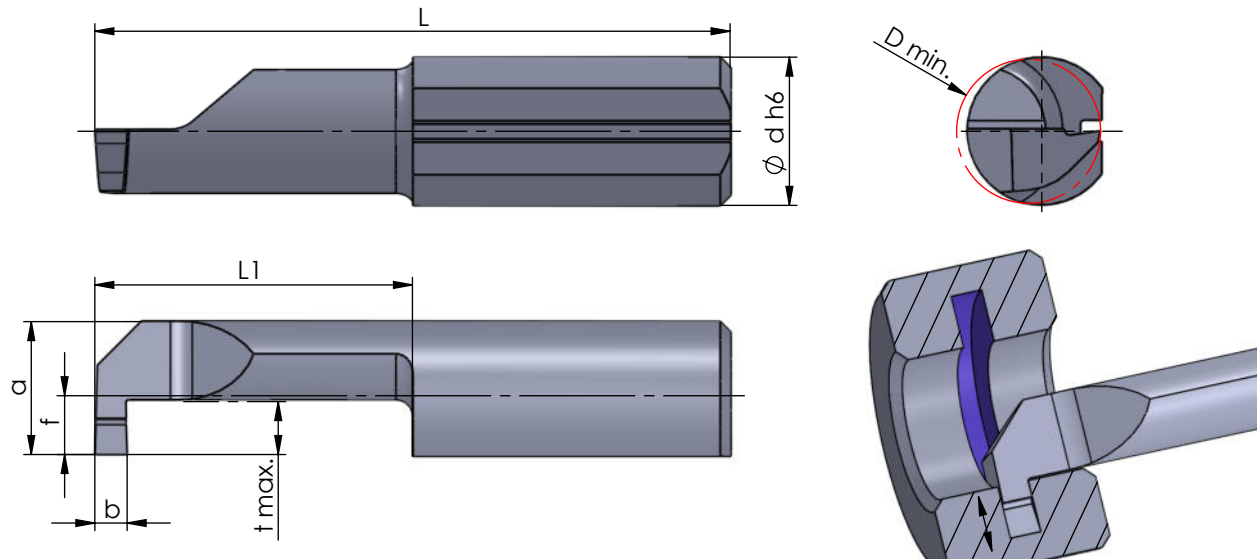

Rechts (R): wie gezeichnet
Links (L): spiegelbildlich

righthand (R): as shown
lefthand version (L): mirror image

Abmessungen in mm

dimensions in mm

Bestellnummer part number	b +0.05	b (inch)	f	a	L	L1	t max.	D min.	\varnothing d h6	Klemmhalter Typ				Klemmhalter Typ toolholder type
										K10F	CN45F	AL41F	PD2F	
R/L 007.0079-10	0.79	0.031"	2.8	6.3	25	10	2.5	6.8	7.0	●		●		670... 676... 687... ...7
R/L 007.0079-25	0.79	0.031"	2.8	6.3	40	25	2.5	6.8	7.0	●		●		
R/L 007.0100-10	1.0		2.8	6.3	25	10	2.5	6.8	7.0	●	●			
R/L 007.0100-15	1.0		2.8	6.3	30	15	2.5	6.8	7.0	●	●			
R/L 007.0100-22	1.0		2.8	6.3	37	22	2.5	6.8	7.0	●	●			
R/L 007.0100-25	1.0		2.8	6.3	40	25	2.5	6.8	7.0	●	●			
R/L 007.0100-30	1.0		2.8	6.3	45	30	2.5	6.8	7.0	●	●			
R/L 007.0100-35	1.0		2.8	6.3	50	35	2.5	7.0	7.0		●			
R/L 007.0100-40	1.0		2.8	6.3	55	40	2.5	7.0	7.0		●			
R/L 007.0100-45	1.0		2.8	6.3	60	45	2.5	7.0	7.0		●			
R/L 007.0100-50	1.0		2.8	6.3	65	50	2.5	7.0	7.0		●			

↳ ...

Weitere HM Sorten können Sie in der Sortenübersicht im Kapitel "Technische Hinweise" und der Preisliste finden.

Bestellbeispiel:
für rechte Ausführung und Sorte
R007.0100-10/CN45F

More carbide grades you can find in the grades summary in the chapter "technical instructions" and in the price list.

order-example:
righthand version and grade
R007.0100-10/CN45F