

ULTRAMINI

Bohrungsbearbeitung
ab \varnothing 0.2 mm

grooving, boring and profiling
starting at \varnothing 0.2 mm

Typ 007M

Stechdrehen
mit Eckenradius

grooving
with corner radius

D min. 6.8 mm
Stechtiefe t max. 2.5 mm

D min. 6.8 mm
depth of groove t max. 2.5 mm

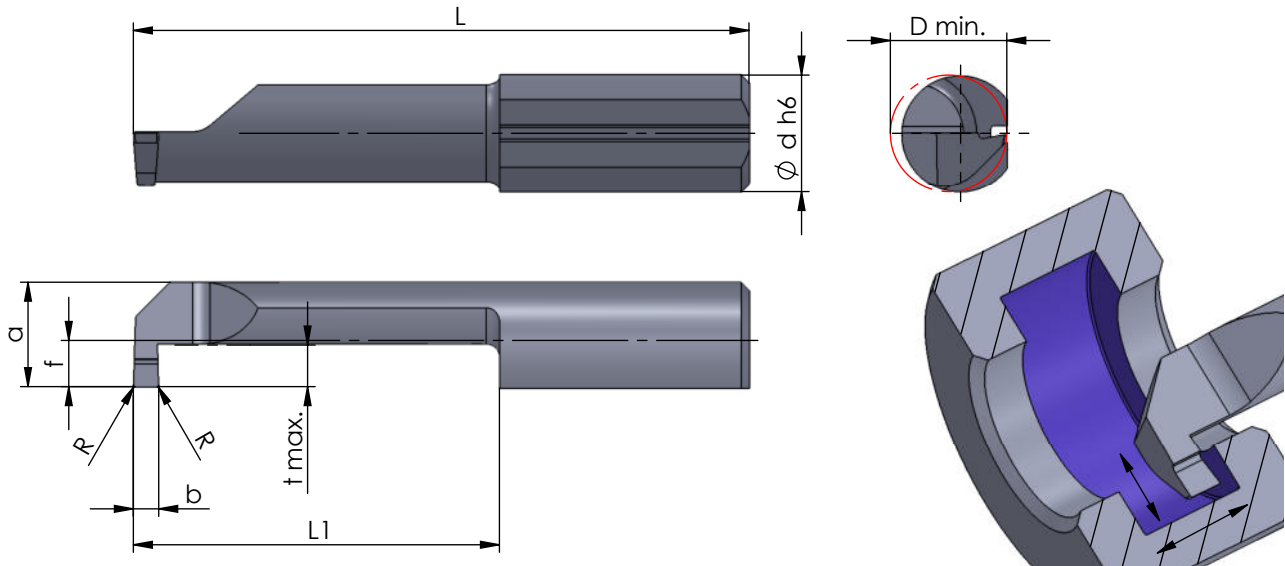

Rechts (R): wie gezeichnet
Links (L): spiegelbildlich

righthand (R): as shown
lefthand version (L): mirror image

Abmessungen in mm

dimensions in mm

Bestellnummer part number	b +0.05	b (inch)	R	f	a	L	L1	t max.	D min.	Ø d h6	Klemmhalter Typ				Klemmhalter Typ toolholder type	
											K10F	CN45F	AL41F	P07C		
R/L 007M0100-10	1.0		0.1	2.8	6.3	25	10	2.5	6.8	7.0		●			670... 676... 687... ...7	
R/L 007M0100-15	1.0		0.1	2.8	6.3	30	15	2.5	6.8	7.0		●				
R/L 007M0100-22	1.0		0.1	2.8	6.3	37	22	2.5	6.8	7.0		●				
R/L 007M0100-25	1.0		0.1	2.8	6.3	40	25	2.5	6.8	7.0		●				
R/L 007M0100-30	1.0		0.1	2.8	6.3	45	30	2.5	6.8	7.0		●				
R/L 007M0117-10	1.17	0.046"	0.1	2.8	6.3	25	10	2.5	6.8	7.0		●				
R/L 007M0117-22	1.17	0.046"	0.1	2.8	6.3	37	22	2.5	6.8	7.0		●				
R/L 007M0150-10	1.5		0.1	2.8	6.3	25	10	2.5	6.8	7.0		●				
R/L 007M0150-15	1.5		0.1	2.8	6.3	30	15	2.5	6.8	7.0		●				
R/L 007M0150-22	1.5		0.1	2.8	6.3	37	22	2.5	6.8	7.0		●				
R/L 007M0150-25	1.5		0.1	2.8	6.3	40	25	2.5	6.8	7.0		●				
R/L 007M0150-30	1.5		0.1	2.8	6.3	45	30	2.5	6.8	7.0		●				
R/L 007M0157-10	1.57	0.062"	0.1	2.8	6.3	25	10	2.5	6.8	7.0		●				
R/L 007M0157-25	1.57	0.062"	0.1	2.8	6.3	40	25	2.5	6.8	7.0		●				
↳ ...																

Weitere HM Sorten können Sie in der Sortenübersicht im Kapitel "Technische Hinweise" und der Preisliste finden.

Bestellbeispiel:
für rechte Ausführung und Sorte
R007M0100-10/AL41F

More carbide grades you can find in the grades summary in the chapter "technical instructions" and in the price list.

order-example:
righthand version and grade
R007M0100-10/AL41F