

# ULTRAMINI

Bohrungsbearbeitung  
ab  $\varnothing$  0.2 mm

grooving, boring and profiling  
starting at  $\varnothing$  0.2 mm

# Typ 004 / 005 / 006 / 007

Stechdrehen und Kopieren  
mit Vollradius

grooving and profiling  
with full radius

D min. 4.0 mm  
Vollradius R 0.5 - 1.0

D min. 4.0 mm  
full radius R 0.5 - 1.0

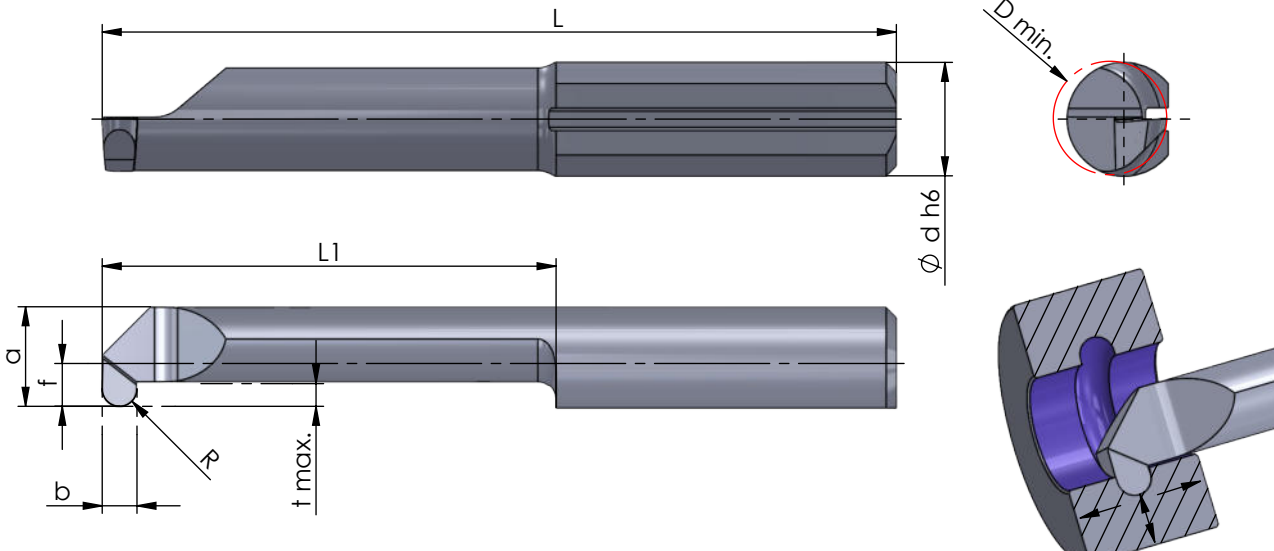

Rechts (R): wie gezeichnet  
Links (L): spiegelbildlich

righthand (R): as shown  
lefthand version (L): mirror image

Abmessungen in mm

dimensions in mm

Bestellnummer part number	b		R	f	a	L	L1	t max.	D min.	Ø d h6	Klemmhalter Typ				Klemmhalter Typ	toolholder type
	+0.05	(inch)									K10F	CN45F	AL41F	PD2F		
R/L004-0.50-16	1.0		0.5	1.5	3.5	30	16	0.8	4.0	4.0	●	●	●			640... ...4
R/L005-0.50-20	1.0		0.5	1.9	4.4	35	20	1.0	5.0	5.0		●	●	645...		640... ...4
R/L005-0.58-20	1.17	0.046"	0.585	1.9	4.4	35	20	1.0	5.0	5.0		●		645...		650... ...5
R/L005-0.75-20	1.5		0.75	1.9	4.4	35	20	1.0	5.0	5.0		●	●	645...		650... ...5
R/L005-1.00-20	2.0		1.0	1.9	4.4	35	20	1.0	5.0	5.0		●	●	645...		650... ...5
R/L006-0.50-25	1.0		0.5	2.3	5.3	40	25	1.8	6.0	6.0	●	●	●			660... ...6
R/L006-0.75-25	1.5		0.75	2.3	5.3	40	25	1.8	6.0	6.0	●	●	●			660... ...6
R/L006-1.00-25	2.0		1.0	2.3	5.3	40	25	1.8	6.0	6.0	●	●	●	676...		660... ...6
R/L007-0.50-30	1.0		0.5	2.8	6.3	45	30	2.5	6.8	7.0		●	●	676...		670... 687... ...7
R/L007-0.75-30	1.5		0.75	2.8	6.3	45	30	2.5	6.8	7.0		●	●	676...		670... 687... ...7
R/L007-1.00-30	2.0		1.0	2.8	6.3	45	30	2.5	6.8	7.0		●	●	676...		670... 687... ...7

Weitere HM Sorten können Sie in der Sortenübersicht im Kapitel "Technische Hinweise" und der Preisliste finden.

Bestellbeispiel:  
für rechte Ausführung und Sorte  
R004-0.50-16/CN45F

More carbide grades you can find in the grades summary in the chapter "technical instructions" and in the price list.

order-example:  
righthand version and grade  
R004-0.50-16/CN45F