

ULTRAMINI

Bohrungsbearbeitung
ab $\varnothing 0.2$ mm

grooving, boring and profiling
starting at $\varnothing 0.2$ mm

Performanceline Typ P55

Ausdrehen und Kopieren
mit Eckenradius 0.05 mm
und innerer Kühlmittelzufuhr

D min. 2.0 - 6.0 mm

boring and profiling
with corner radius 0.05 mm
and through coolant

D min. 2.0 - 6.0 mm

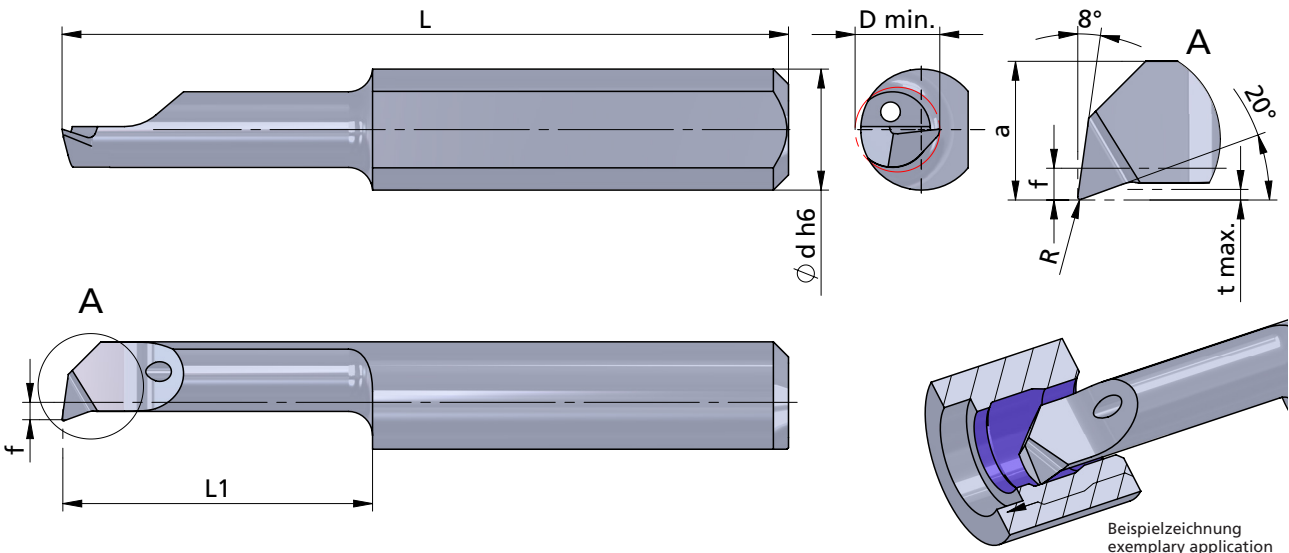

Rechts (R): wie gezeichnet
Links (L): spiegelbildlich

righthand (R): as shown
lefthand version (L): mirror image

Abmessungen in mm

dimensions in mm

	Bestellnummer part number	R	f	a	L	L1	t max.	D min.	\varnothing d h6	K10F	P04C	AL41F	PD2F	Klemmhalter Typ	toolholder type
	...														
neu	R/L P55.5-10	0.05	1.9	4.4	25	10	0.5	5.0	5.0		●				
neu	R/L P55.5-15	0.05	1.9	4.4	30	15	0.5	5.0	5.0		●				
neu	R/L P55.5-20	0.05	1.9	4.4	35	20	0.5	5.0	5.0		●				
neu	R/L P55.5-25	0.05	1.9	4.4	40	25	0.5	5.0	5.0		●			645... 650... ...5	
neu	R/L P55.5-30	0.05	1.9	4.4	45	30	0.5	5.0	5.0		●				
neu	R/L P55.5-35	0.05	1.9	4.4	50	35	0.5	5.0	5.0		●				
neu	R/L P55.6-15	0.05	2.3	5.3	30	15	0.5	6.0	6.0		●				
neu	R/L P55.6-22	0.05	2.3	5.3	37	22	0.5	6.0	6.0		●				
neu	R/L P55.6-25	0.05	2.3	5.3	40	25	0.5	6.0	6.0		●				
neu	R/L P55.6-30	0.05	2.3	5.3	45	30	0.5	6.0	6.0		●			660... 676... ...6	
neu	R/L P55.6-35	0.05	2.3	5.3	50	35	0.5	6.0	6.0		●				
neu	R/L P55.6-42	0.05	2.3	5.3	57	42	0.5	6.0	6.0		●				

Weitere HM Sorten können Sie in der Sortenübersicht im Kapitel "Technische Hinweise" und der Preisliste finden.

Bestellbeispiel:
für rechte Ausführung und Sorte
RP55.5-10/P04C

More carbide grades you can find in the grades summary in the chapter "technical instructions" and in the price list.

order-example:
righthand version and grade
RP55.5-10/P04C