

ULTRAMINI

Bohrungsbearbeitung
ab \varnothing 0.2 mm

grooving, boring and profiling
starting at \varnothing 0.2 mm

Performanceline Typ P50....C

Ausdrehen und Kopieren
mit Spantreppe
für bessere Spankontrolle
und innerer Kühlmittelzufuhr

boring and profiling
with chipbreaker
for better chipcontrol
and through coolant

D min. 2.0 - 6.8 mm
Auskrägung (L1) bis 7x D

D min. 2.0 - 6.8 mm
overhang length (L1) up to 7x D

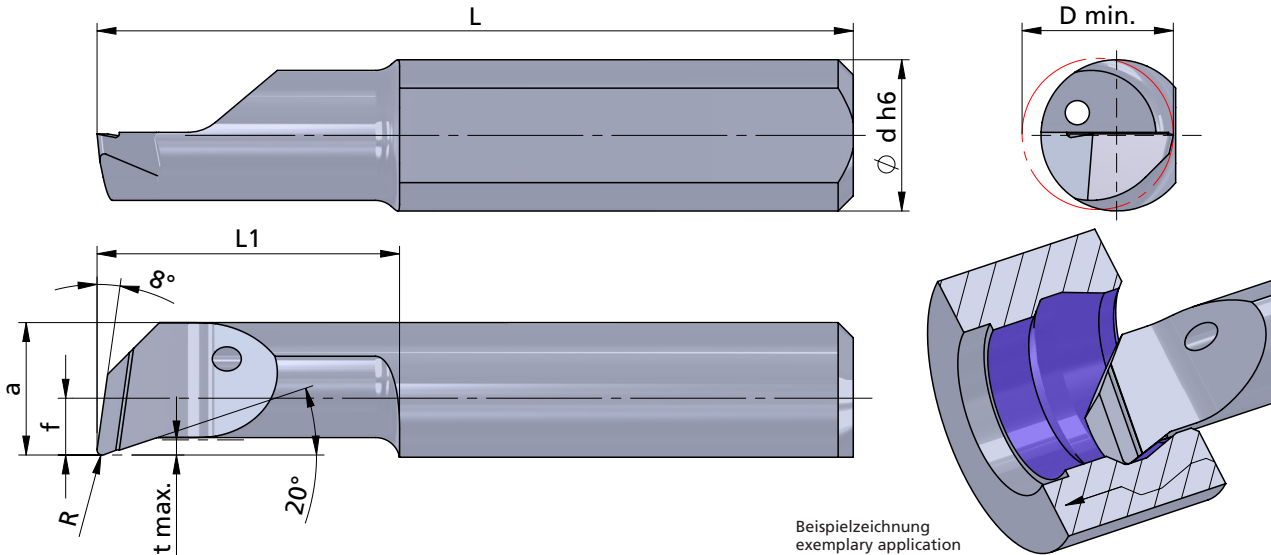

Beispielzeichnung
exemplary application

Rechts (R): wie gezeichnet
Links (L): spiegelbildlich

righthand (R): as shown
lefthand version (L): mirror image

Abmessungen in mm

dimensions in mm

Bestellnummer part number	R	f	a	L	L1	t max.	D min.	Ø d h6	K10F P04C AL41F PD2F	Klemmhalter Typ toolholder type
neu R/L P50.6-15C	0.15	2.3	5.3	30	15	0.5	6.0	6.0	●	676... 670... 687... ...7
neu R/L P50.6-22C	0.15	2.3	5.3	37	22	0.5	6.0	6.0	●	
neu R/L P50.6-25C	0.15	2.3	5.3	40	25	0.5	6.0	6.0	●	
neu R/L P50.6-30C	0.15	2.3	5.3	45	30	0.5	6.0	6.0	●	
neu R/L P50.6-35C	0.15	2.3	5.3	50	35	0.5	6.0	6.0	●	
neu R/L P50.6-42C	0.15	2.3	5.3	57	42	0.5	6.0	6.0	●	
neu R/L P50.7-20C	0.15	2.8	6.3	35	20	0.6	6.8	7.0	●	676... 670... 687... ...7
neu R/L P50.7-25C	0.15	2.8	6.3	40	25	0.6	6.8	7.0	●	
neu R/L P50.7-30C	0.15	2.8	6.3	45	30	0.6	6.8	7.0	●	
neu R/L P50.7-35C	0.15	2.8	6.3	50	35	0.6	6.8	7.0	●	
neu R/L P50.7-40C	0.15	2.8	6.3	55	40	0.6	6.8	7.0	●	
neu R/L P50.7-45C	0.15	2.8	6.3	60	45	0.6	6.8	7.0	●	
neu R/L P50.7-50C	0.15	2.8	6.3	65	50	0.6	6.8	7.0	●	

Weitere HM Sorten können Sie in der Sortenübersicht im Kapitel "Technische Hinweise" und der Preisliste finden.

Bestellbeispiel:
für rechte Ausführung und Sorte
RP50.6-15C/P04C

More carbide grades you can find in the grades summary in the chapter "technical instructions" and in the price list.

order-example:
righthand version and grade
RP50.6-15C/P04C