

ULTRAMINI

Bohrungsbearbeitung
ab $\varnothing 0.2$ mm

grooving, boring and profiling
starting at $\varnothing 0.2$ mm

Performanceline Typ P47

Audreihen und Kopieren
mit Geometrie $47^\circ / 8^\circ$
und innerer Kühlmittelzufuhr

D min. 2.0 - 6.0 mm

boring and profiling
with geometry $47^\circ / 8^\circ$
and through coolant

D min. 2.0 - 6.0 mm

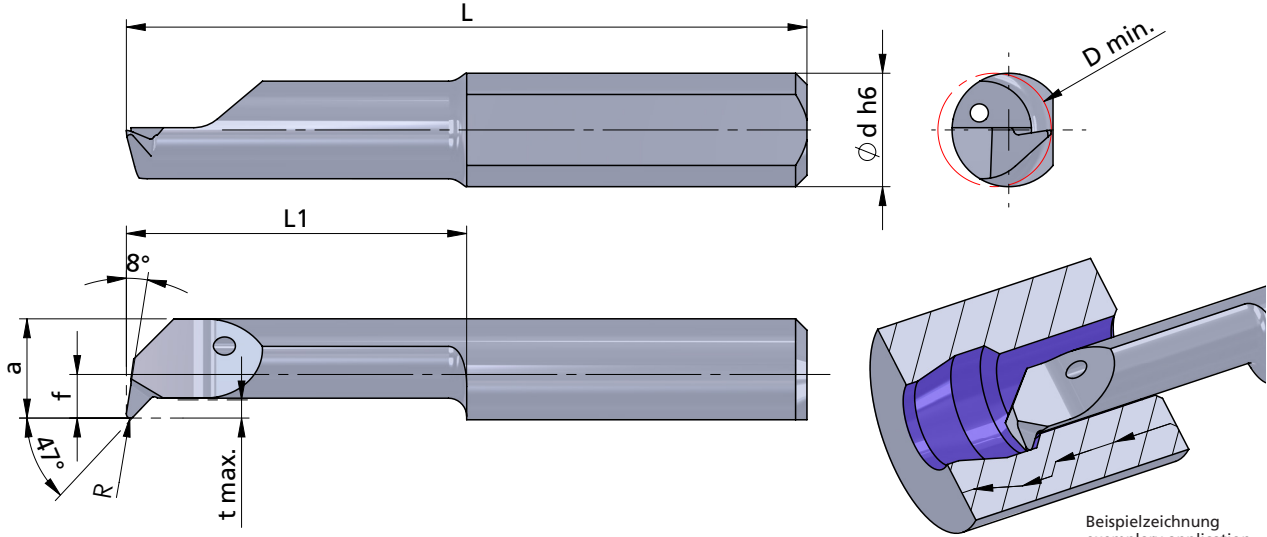

Rechts (R): wie gezeichnet
Links (L): spiegelbildlich

righthand (R): as shown
lefthand version (L): mirror image

Abmessungen in mm

dimensions in mm

	Bestellnummer part number	R	f	a	L	L1	t max.	D min.	Ø d h6	K10F P04C AL41F P07C	Klemmhalter Typ toolholder type
neu	R/L P47T2-10	0.05		1.7	24	10	0.4	2.0	4.0	●	645... 640... ...4
neu	R/L P47T3-15	0.1	0.6	2.6	29	15	0.6	2.8	4.0	●	
neu	R/L P47T4-10	0.1	1.5	3.5	24	10	0.6	4.0	4.0	●	
neu	R/L P47.4-20	0.1	1.5	3.5	34	20	0.3	4.0	4.0	●	
neu	R/L P47T4-20	0.1	1.5	3.5	34	20	0.6	4.0	4.0	●	
neu	R/L P47T5-15	0.15	1.9	4.4	30	15	0.8	5.0	5.0	●	650... ...5
neu	R/L P47.5-25	0.15	1.9	4.4	40	25	0.5	5.0	5.0	●	
neu	R/L P47T5-25	0.15	1.9	4.4	40	25	0.8	5.0	5.0	●	676... 660... ...6
neu	R/L P47T6-22	0.15	2.3	5.3	37	22	1.8	6.0	6.0	●	
neu	R/L P47.6-30	0.15	2.3	5.3	45	30	0.5	6.0	6.0	●	
neu	R/L P47T6-30	0.15	2.3	5.3	45	30	1.8	6.0	6.0	●	

Weitere HM Sorten können Sie in der Sortenübersicht im Kapitel "Technische Hinweise" und der Preisliste finden.

Bestellbeispiel:
für rechte Ausführung und Sorte
RP47T2-10/P04C

More carbide grades you can find in the grades summary in the chapter "technical instructions" and in the price list.

order-example:
righthand version and grade
RP47T2-10/P04C