

MINIMILL XL

Nutfräsen, Trennfräsen und Schlitzfräsen

groove and slot milling

Typ X1250.X

Nutfräsen, Trennfräsen und Schlitzfräsen

groove and slot milling

Ø DS 50
t max. = 16.5
b = 1.5 - 3.0

Ø DS 50
t max. = 16.5
b = 1.5 - 3.0

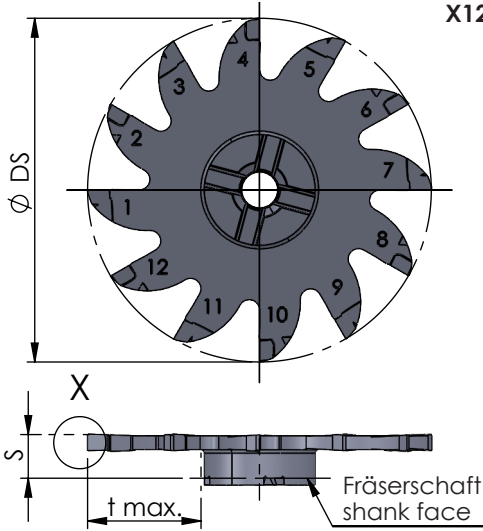

X1250.X kreuzverzahnt / staggered-toothed

Schneide / tooth
1-3-5-7-9-11

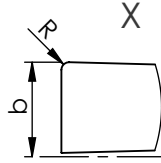

Schneide / tooth
2-4-6-8-10-12

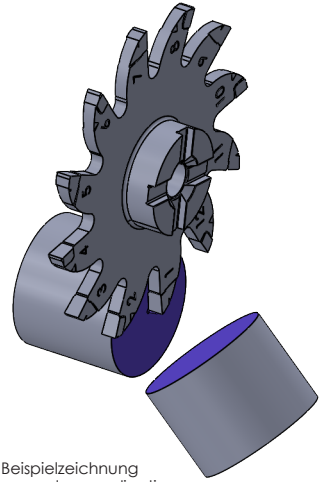
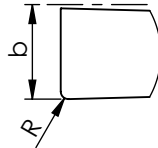

Beispielzeichnung
exemplary application

Abmessungen in mm

dimensions in mm

Bestellnummer part number	Ø DS	S	R	b ±0.02	t max.	Zähnezahl number of teeth	K10F P04C		für Frälerschaft for milling shank
neu X1250.X150.01	50	6.35	0.1	1.5	16.5	12	●	●	XH50...
neu X1250.X200.02	50	6.35	0.2	2.0	16.5	12	●	●	
neu X1250.X250.02	50	6.35	0.2	2.5	16.5	12	●	●	
neu X1250.X300.02	50	6.35	0.2	3.0	16.5	12	●	●	

Weitere HM Sorten können Sie in der Sortenübersicht im Kapitel "Technische Hinweise" und der Preisliste finden.

Bestellbeispiel:
für Sorte P04C:
X1250.X150.01/P04C

More carbide grades you can find in the grades summary in the chapter "technical instructions" and in the price list.

order-example:
grade P04C:
X1250.X150.01/P04C