

ULTRAMINI

Bohrungsbearbeitung
ab Ø 0.2 mm

grooving, boring and profiling
starting at Ø 0.2 mm

Performanceline Typ P05M

Stechdrehen
mit Eckenradius
und innerer Kühlmittelzufuhr

grooving
with corner radius
and through coolant

D min. 5.0 mm
Stechtiefe t max. 1.0 mm

D min. 5.0 mm
depth of groove t max. 1.0 mm

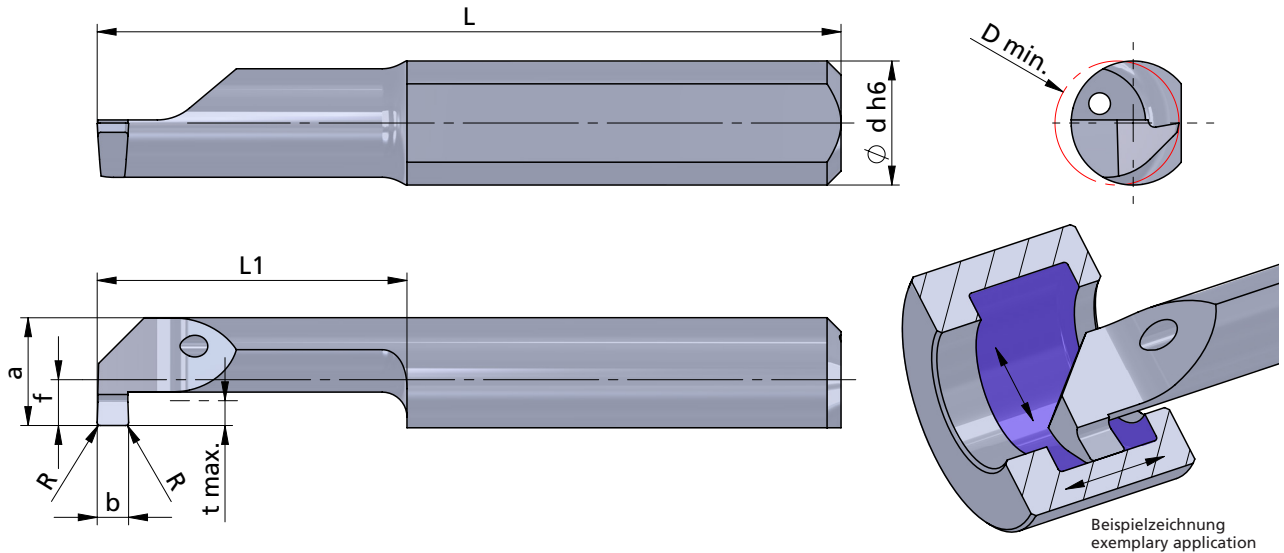

Rechts (R): wie gezeichnet
Links (L): spiegelbildlich

righthand (R): as shown
lefthand version (L): mirror image

Abmessungen in mm

dimensions in mm

	Bestellnummer part number	b +0.05	b (inch)	R	f	a	L	L1	t max.	D min.	Ø d h6	Klemmhalter Typ toolholder type			
												K10F	P04C	AL41F	P07C
neu	R/L P05M0200-10	2.0	0.1	1.9	4.4	25	10	1.0	5.0	5.0	●				
neu	R/L P05M0200-15	2.0	0.1	1.9	4.4	30	15	1.0	5.0	5.0	●				
neu	R/L P05M0200-20	2.0	0.1	1.9	4.4	35	20	1.0	5.0	5.0	●				645... 650... ...5
neu	R/L P05M0200-25	2.0	0.1	1.9	4.4	40	25	1.0	5.0	5.0	●				
neu	R/L P05M0200-30	2.0	0.1	1.9	4.4	45	30	1.0	5.0	5.0	●				

Weitere HM Sorten können Sie in der Sortenübersicht im Kapitel "Technische Hinweise" und der Preisliste finden.

Bestellbeispiel:
für rechte Ausführung und Sorte
RP05M0200-10/P04C

More carbide grades you can find in the grades summary in the chapter "technical instructions" and in the price list.

order-example:
righthand version and grade
RP05M0200-10/P04C