

# ULTRAMINI

Bohrungsbearbeitung  
ab  $\varnothing$  0.2 mm

grooving, boring and profiling  
starting at  $\varnothing$  0.2 mm

# Performanceline Typ P07M

Stechdrehen  
mit Eckenradius  
und innerer Kühlmittelzufuhr

grooving  
with corner radius  
and through coolant

D min. 6.8 mm  
Stechtiefe t max. 2.5 mm

D min. 6.8 mm  
depth of groove t max. 2.5 mm

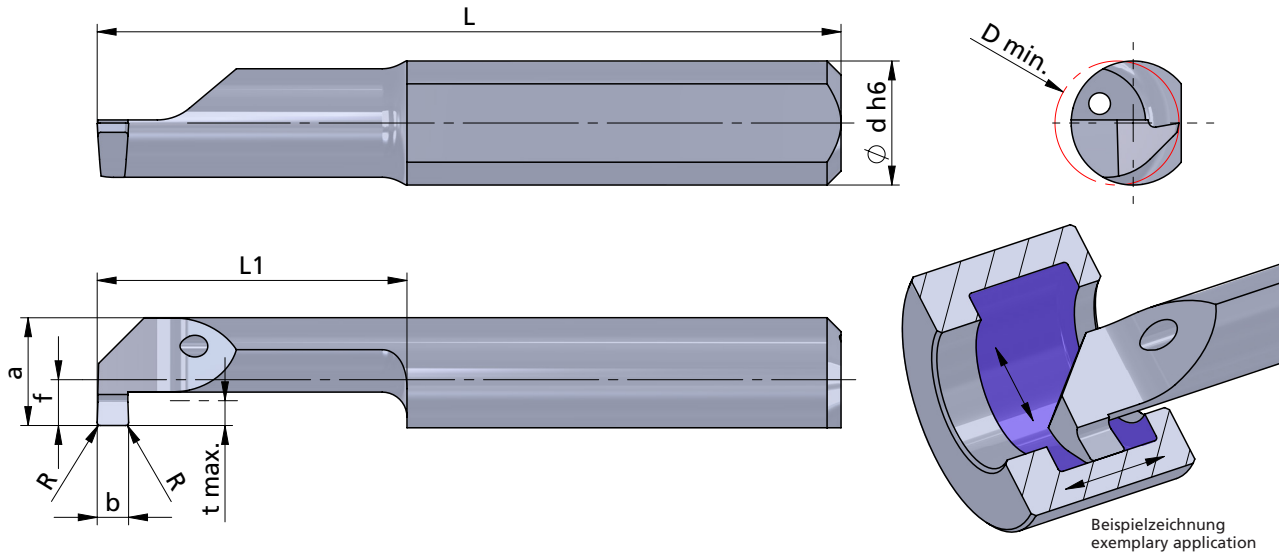

Beispielzeichnung  
exemplary application

Rechts (R): wie gezeichnet  
Links (L): spiegelbildlich

righthand (R): as shown  
lefthand version (L): mirror image

Abmessungen in mm

dimensions in mm

	Bestellnummer part number	b +0.05	b (inch)	R	f	a	L	L1	t max.	D min.	Ø d h6	Klemmhalter Typ toolholder type				
												K10F	P04C	AL41F	P07C	
neu	R/L P07M0198-22	1.98	0.078"	0.1	2.8	6.3	37	22	2.5	6.8	7.0	●				
neu	R/L P07M0200-10	2.0		0.1	2.8	6.3	25	10	2.5	6.8	7.0	●				
neu	R/L P07M0200-15	2.0		0.1	2.8	6.3	30	15	2.5	6.8	7.0	●				
neu	R/L P07M0200-22	2.0		0.1	2.8	6.3	37	22	2.5	6.8	7.0	●			670...	676...
neu	R/L P07M0200-25	2.0		0.1	2.8	6.3	40	25	2.5	6.8	7.0	●			687...	...7
neu	R/L P07M0200-30	2.0		0.1	2.8	6.3	45	30	2.5	6.8	7.0	●				

Weitere HM Sorten können Sie in der Sortenübersicht im Kapitel "Technische Hinweise" und der Preisliste finden.

Bestellbeispiel:  
für rechte Ausführung und Sorte  
RP07M0198-22/P04C

More carbide grades you can find in the grades summary in the chapter "technical instructions" and in the price list.

order-example:  
righthand version and grade  
RP07M0198-22/P04C