

## ULTRAMINI

Bohrungsbearbeitung  
ab  $\varnothing$  0.2 mm

grooving, boring and profiling  
starting at  $\varnothing$  0.2 mm

## Performanceline Typ P04 / P05 / P06 / P07

Stechdrehen und Kopieren  
mit Vollradius  
und innerer Kühlmittelzufuhr

D min. 4.0 - 6.8 mm  
Vollradius R 0.5 - 1.0

grooving and profiling  
with full radius  
and through coolant

D min. 4.0 - 6.8 mm  
full radius R 0.5 - 1.0

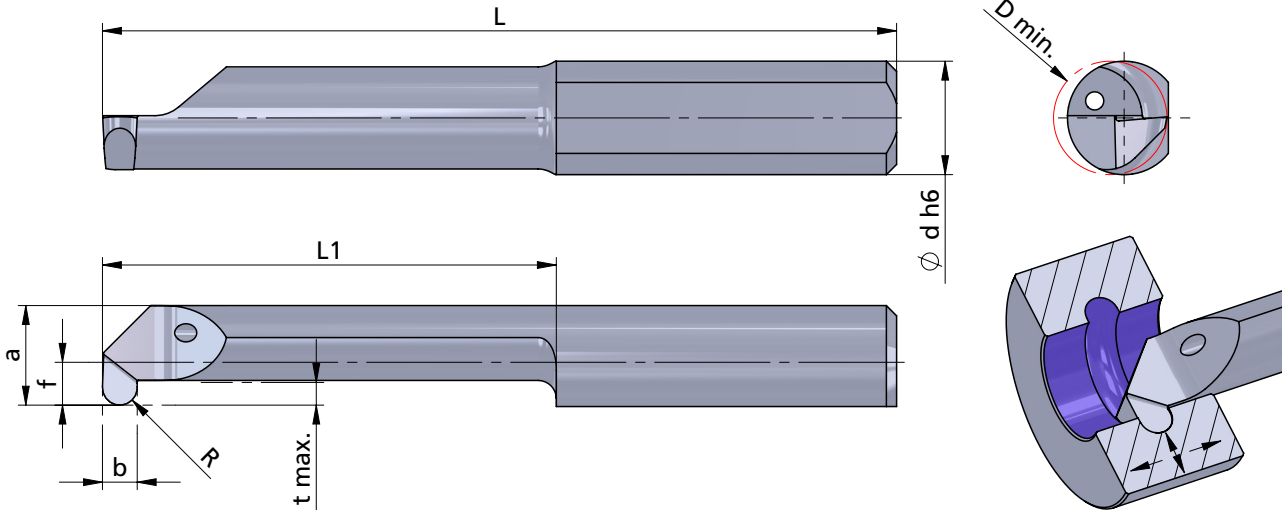

Rechts (R): wie gezeichnet  
Links (L): spiegelbildlich

righthand (R): as shown  
lefthand version (L): mirror image

Abmessungen in mm

dimensions in mm

	Bestellnummer part number	b +0.05	b (inch)	R	f	a	L	L1	t max.	D min.	$\varnothing$ d h6	Klemmhalter Typ toolholder type			
												K10F	P04C	AL41F	PD2F
neu	R/L P04-0.50-16	1.0		0.5	1.5	3.5	30	16	0.8	4.0	4.0	●			640... ...4
neu	R/L P05-0.50-20	1.0		0.5	1.9	4.4	35	20	1.0	5.0	5.0	●		645...	
neu	R/L P05-0.58-20	1.17	0.046"	0.585	1.9	4.4	35	20	1.0	5.0	5.0	●		645...	650... ...5
neu	R/L P05-0.75-20	1.5		0.75	1.9	4.4	35	20	1.0	5.0	5.0	●		645...	
neu	R/L P05-1.00-20	2.0		1.0	1.9	4.4	35	20	1.0	5.0	5.0	●		645...	
neu	R/L P06-0.50-25	1.0		0.5	2.3	5.3	40	25	1.8	6.0	6.0	●		676...	
neu	R/L P06-0.75-25	1.5		0.75	2.3	5.3	40	25	1.8	6.0	6.0	●		676...	660... ...6
neu	R/L P06-1.00-25	2.0		1.0	2.3	5.3	40	25	1.8	6.0	6.0	●		676...	
neu	R/L P07-0.50-30	1.0		0.5	2.8	6.3	45	30	2.5	6.8	7.0	●		676...	
neu	R/L P07-0.75-30	1.5		0.75	2.8	6.3	45	30	2.5	6.8	7.0	●		676...	670... 687... ...7
neu	R/L P07-1.00-30	2.0		1.0	2.8	6.3	45	30	2.5	6.8	7.0	●		676...	

Weitere HM Sorten können Sie in der Sortenübersicht im Kapitel "Technische Hinweise" und der Preisliste finden.

Bestellbeispiel:  
für rechte Ausführung und Sorte  
RP04-0.50-16/P04C

More carbide grades you can find in the grades summary in the chapter "technical instructions" and in the price list.

order-example:  
righthand version and grade  
RP04-0.50-16/P04C