

ULTRAMINI

Bohrungsbearbeitung
ab \varnothing 0.2 mm

grooving, boring and profiling
starting at \varnothing 0.2 mm

Performanceline Typ Gewindedrehen

metrisches ISO-Gewinde,
Teilprofil, innen
mit innerer Kühlmittelzufuhr

type threading,
metric ISO-thread,
partial profile, internal
with through coolant

D min. 1.56 - 7.0 mm
Steigung P = 0.4 - 1.75

D min. 1.56 - 7.0 mm
pitch P = 0.4 - 1.75

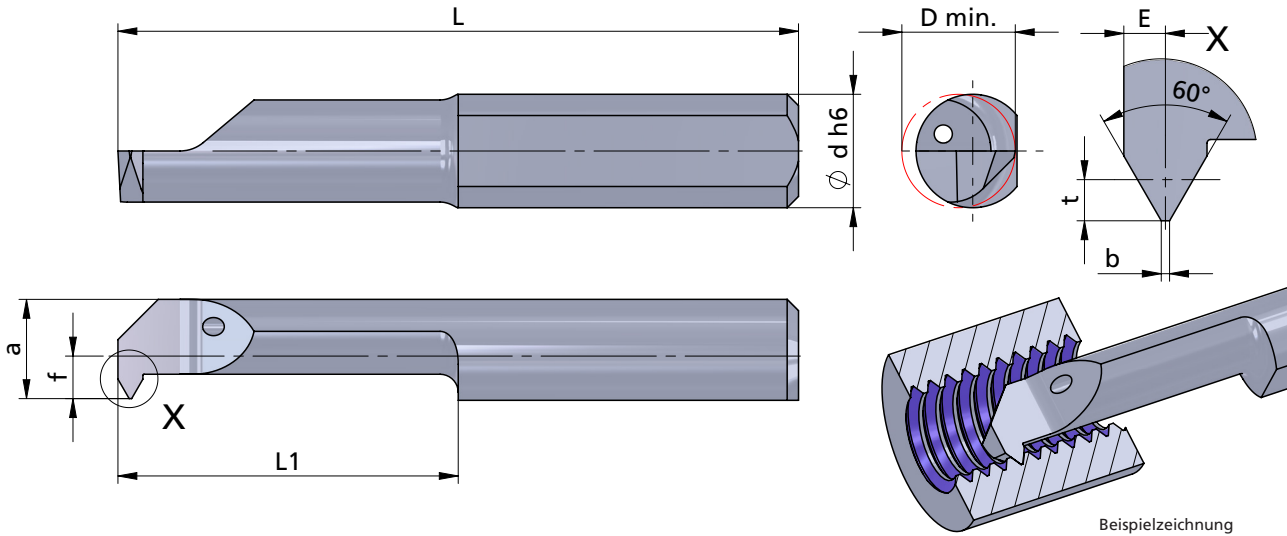

Beispielzeichnung
exemplary application

Rechts (R): wie gezeichnet
Links (L): spiegelbildlich

righthand (R): as shown
lefthand version (L): mirror image

Abmessungen in mm

dimensions in mm

	Bestellnummer part number	Steigung P pitch P	Regelgewinde / standard thread	t	E	b	f	a	L	L1	D min.	\varnothing d h6	Klemmhalter Typ				Klemmhalter Typ toolholder type
													K10F	P04C	AL41F	PD2F	
neu	R/L P06.0510-15	1.0 - 1.25		0.55	0.55	0.12	2.3	5.3	30	15	6.0	6.0	●				
neu	R/L P06.0510-22	1.0 - 1.25		0.55	0.55	0.12	2.3	5.3	37	22	6.0	6.0	●				
neu	R/L P06.0612-15	1.25 - 1.5	M8	0.68	0.65	0.15	2.3	5.3	30	15	6.0	6.0	●				660... ...6
neu	R/L P06.0612-22	1.25 - 1.5	M8	0.68	0.65	0.15	2.3	5.3	37	22	6.0	6.0	●				660... ...6
neu	R/L P06.0815-15	1.5 - 1.75	M10	0.81	0.75	0.18	2.3	5.3	30	15	6.0	6.0	●				676...
neu	R/L P06.0815-22	1.5 - 1.75	M10	0.81	0.75	0.18	2.3	5.3	37	22	6.0	6.0	●				676...
neu	R/L P07.0815-15	1.5 - 1.75	M10	0.81	0.75	0.18	2.7	6.3	30	15	7.0	7.0	●				670... 687... ...7
neu	R/L P07.0815-25	1.5 - 1.75	M10	0.81	0.75	0.18	2.7	6.3	40	25	7.0	7.0	●				670... 687... ...7

Weitere HM Sorten können Sie in der Sortenübersicht im Kapitel "Technische Hinweise" und der Preisliste finden.

Bestellbeispiel:
für rechte Ausführung und Sorte
RP06.0510-15/P04C

weitere Informationen:
• siehe Technische Hinweise

more informations:
• look at the technical instructions

More carbide grades you can find in the grades summary in the chapter "technical instructions" and in the price list.

order-example:
righthand version and grade
RP06.0510-15/P04C