

ULTRAMINI

Bohrungsbearbeitung
ab \varnothing 0.2 mm

grooving, boring and profiling
starting at \varnothing 0.2 mm

Performanceline Typ Gewindedrehen

metrisches ISO-Gewinde,
Vollprofil, innen
mit innerer Kühlmittelzufuhr

type threading,
metric ISO-thread,
full profile, internal
with through coolant

D min. 4.0 - 7.0 mm
Steigung P = 0.5 - 1.5

D min. 4.0 - 7.0 mm
pitch P = 0.5 - 1.5

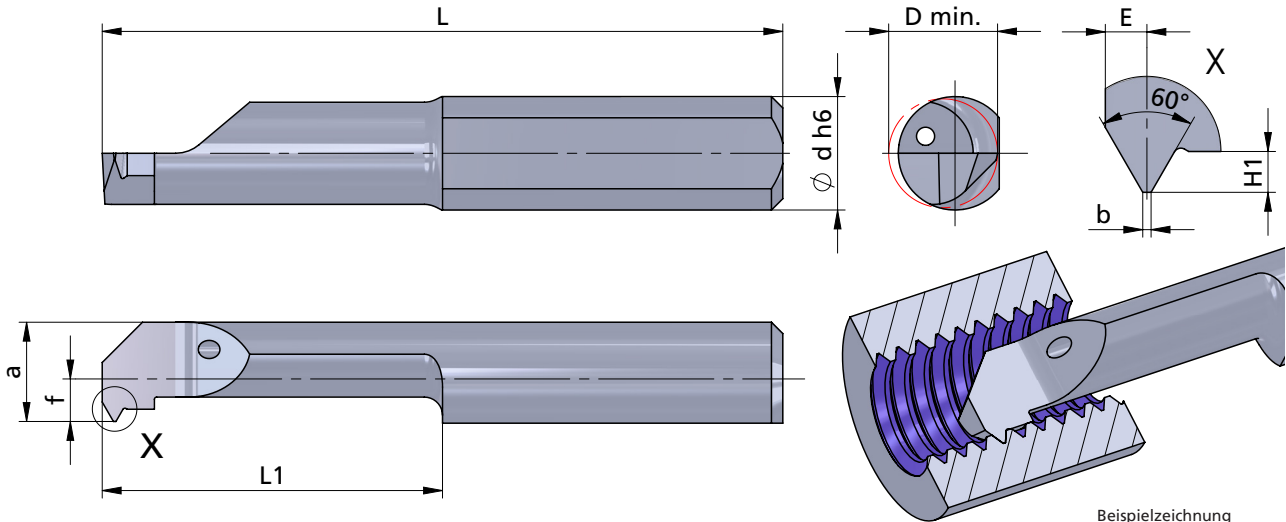

Beispielzeichnung
exemplary application

Rechts (R): wie gezeichnet
Links (L): spiegelbildlich

righthand (R): as shown
lefthand version (L): mirror image

Abmessungen in mm

dimensions in mm

Bestellnummer part number	Steigung P pitch P	Regelgewinde / standard thread	H1	E	b	f	a	L	L1	D min.	Ø d h6	Klemmhalter Typ				Klemmhalter Typ	toolholder type
												K10F	P04C	AL41F	PD2F		
neu R/L 1P4.0205-15	0.5		0.27	0.35	0.06	1.5	3.5	30	15	4.0	4.0	●					640... ...4
neu R/L 1P4.0408-15	0.8	M5	0.43	0.5	0.10	1.5	3.5	30	15	4.0	4.0	●					640... ...4
neu R/L 1P5.0205-15	0.5		0.27	0.35	0.06	1.9	4.4	30	15	5.0	5.0	●			645...		640... ...4
neu R/L 1P5.0407-15	0.75		0.40	0.45	0.09	1.9	4.4	30	15	5.0	5.0	●			645...		650... ...5
neu R/L 1P5.0408-15	0.8		0.43	0.50	0.10	1.9	4.4	30	15	4.8	5.0	●			645...		650... ...5
neu R/L 1P5.0510-15	1.0	M6	0.54	0.55	0.12	1.9	4.4	30	15	4.8	5.0	●			645...		650... ...5
neu R/L 1P6.0510-15	1.0		0.54	0.55	0.12	2.3	5.3	30	15	6.0	6.0	●			676...		660... ...6
neu R/L 1P6.0612-15	1.25	M8	0.67	0.65	0.15	2.3	5.3	30	15	6.0	6.0	●			676...		660... ...6
neu R/L 1P6.0815-15	1.5	M10	0.81	0.75	0.18	2.3	5.3	30	15	6.0	6.0	●			676...		660... ...6
neu R/L 1P7.0815-15	1.5	M10	0.81	0.75	0.18	2.8	6.3	30	15	7.0	7.0	●			676...		670... 687... ...7

Weitere HM Sorten können Sie in der Sortenübersicht im Kapitel "Technische Hinweise" und der Preisliste finden.

Bestellbeispiel:
für rechte Ausführung und Sorte
R1P4.0205-15/P04C

weitere Informationen:

- siehe Technische Hinweise

more informations:

- look at the technical instructions

More carbide grades you can find in the grades summary in the chapter "technical instructions" and in the price list.

order-example:
righthand version and grade
R1P4.0205-15/P04C