

ULTRAMINI

Bohrungsbearbeitung
ab $\varnothing 0.2 \text{ mm}$

grooving, boring and profiling
starting at $\varnothing 0.2 \text{ mm}$

Performanceline Typ P10M

Axialstechen
mit Eckenradius
und innerer Kühlmittelzufuhr

face grooving
with corner radius
and through coolant

D min. 8.0 mm
Stechtiefe t max. 6.0 mm
Nutbreite bis 3.0 mm

D min. 8.0 mm
depth of groove t max. 6.0 mm
width of groove up to 3.0 mm

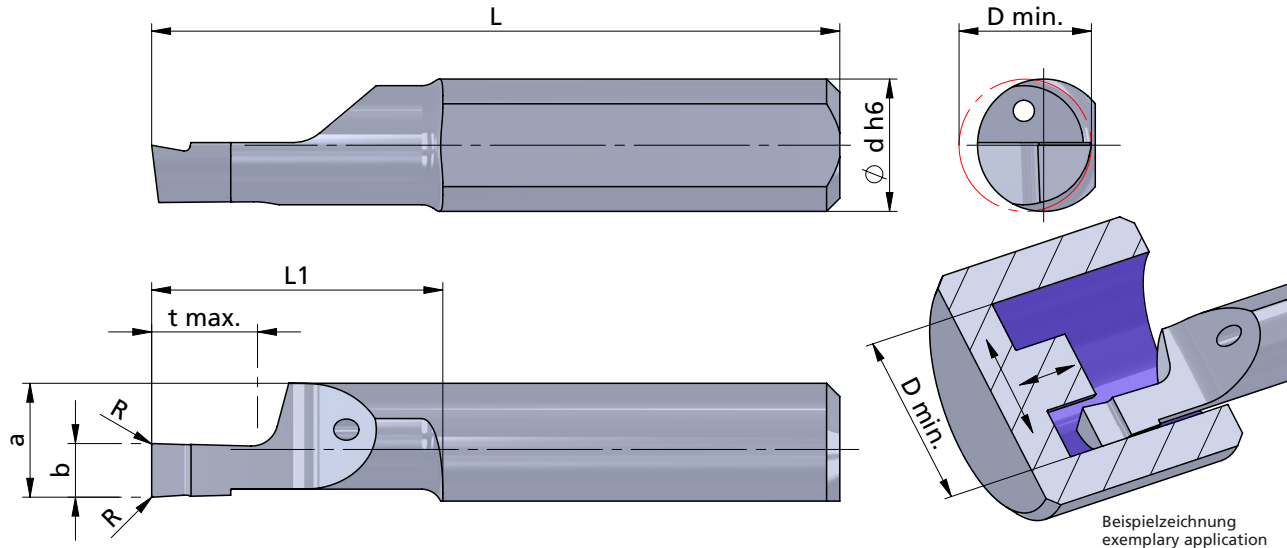

Rechts (R): wie gezeichnet
Links (L): spiegelbildlich

righthand (R): as shown
lefthand version (L): mirror image

Abmessungen in mm

dimensions in mm

	Bestellnummer part number	b +0.05	b (inch)	a	L	L1	t max.	D min.	Ø d h6	R	Klemmhalter Typ toolholder type				
											K10F	P04C	AL41F	P07C	
neu	R/L P10M1008-10	1.0		5.9	26	11	2.0	8.0	7.0	0.1	●				
neu	R/L P10M1508-10	1.5		5.9	26	11	3.0	8.0	7.0	0.1	●				
neu	R/L P10M1578-10	1.57	0.062"	5.9	26	11	3.0	8.0	7.0	0.1	●				
neu	R/L P10M2008-10	2.0		5.9	26	11	4.0	8.0	7.0	0.1	●				
neu	R/L P10M2508-10	2.5		5.9	26	11	5.0	8.0	7.0	0.1	●				
neu	R/L P10M3008-10	3.0		5.9	26	11	6.0	8.0	7.0	0.1	●				
neu	R/L P10M1008-20	1.0		5.9	35	20	2.0	8.0	7.0	0.1	●				670... 676... 687... ...7
neu	R/L P10M1508-20	1.5		5.9	35	20	3.0	8.0	7.0	0.1	●				
neu	R/L P10M2008-20	2.0		5.9	35	20	4.0	8.0	7.0	0.1	●				
neu	R/L P10M2308-20	2.38	0.094"	5.9	35	20	5.0	8.0	7.0	0.1	●				
neu	R/L P10M2508-20	2.5		5.9	35	20	5.0	8.0	7.0	0.1	●				
neu	R/L P10M3008-20	3.0		5.9	35	20	6.0	8.0	7.0	0.1	●				
	↳ ...														

Weitere HM Sorten können Sie in der Sortenübersicht im Kapitel "Technische Hinweise" und der Preisliste finden.

Bestellbeispiel:
für rechte Ausführung und Sorte
RP10M1008-10/P04C

More carbide grades you can find in the grades summary in the chapter "technical instructions" and in the price list.

order-example:
righthand version and grade
RP10M1008-10/P04C