

ULTRAMINI

Bohrungsbearbeitung
ab \varnothing 0.2 mm

grooving, boring and profiling
starting at \varnothing 0.2 mm

Performanceline Typ P10

Axialstechen
mit Vollradius
und innerer Kühlmittelzufuhr

face grooving
with full radius
and through coolant

D min. 8.0 mm
Stechtiefe t max. 6.0 mm
Nutbreite bis 3.0 mm

D min. 8.0 mm
depth of groove t max. 6.0 mm
width of groove up to 3.0 mm

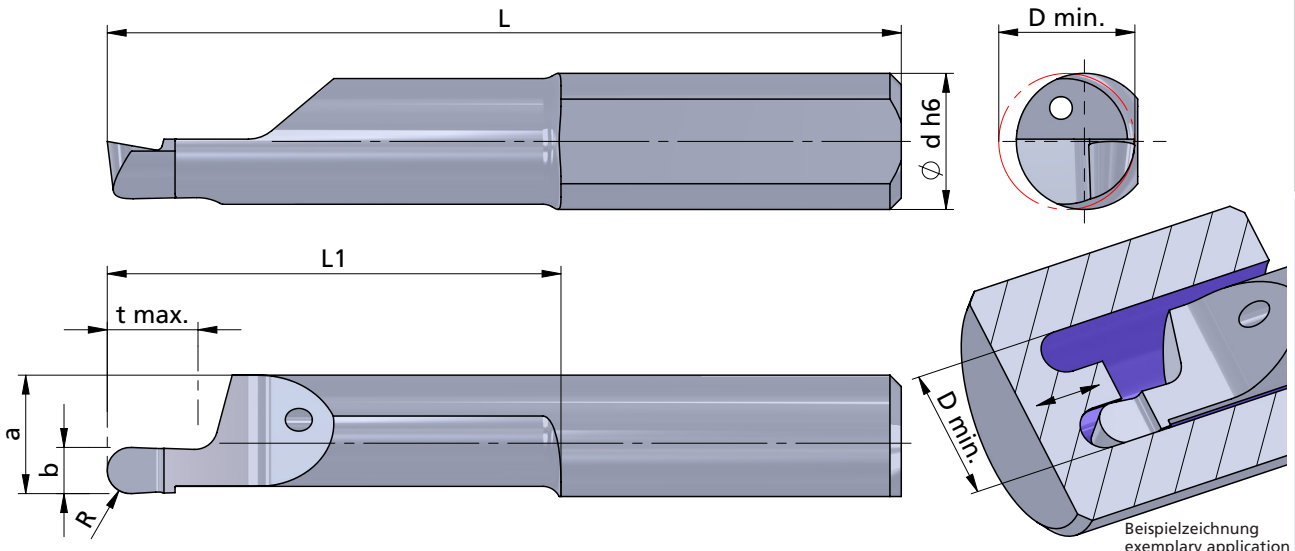

Rechts (R): wie gezeichnet
Links (L): spiegelbildlich

righthand (R): as shown
lefthand version (L): mirror image

Abmessungen in mm

dimensions in mm

	Bestellnummer part number	b		R	a	L	L1	t max.	D min.	Ø d h6	Klemmhalter Typ toolholder type				
		b +0.05	b (inch)								K10F	P04C	AL41F	PD2F	
neu	R/L P10.1005-10	1.0		0.5	5.9	26	11	2.0	8.0	7.0	●				
neu	R/L P10.1507-10	1.57	0.062"	0.78	5.9	26	11	3.0	8.0	7.0	●				
neu	R/L P10.1608-10	1.6		0.8	5.9	26	11	3.0	8.0	7.0	●				
neu	R/L P10.1910-10	1.98	0.078"	0.99	5.9	26	11	4.0	8.0	7.0	●				
neu	R/L P10.2010-10	2.0		1.0	5.9	26	11	4.0	8.0	7.0	●				
neu	R/L P10.2512-10	2.5		1.25	5.9	26	11	5.0	8.0	7.0	●				
neu	R/L P10.3015-10	3.0		1.5	5.9	26	11	6.0	8.0	7.0	●				
neu	R/L P10.1005-20	1.0		0.5	5.9	35	20	2.0	8.0	7.0	●				
neu	R/L P10.1608-20	1.6		0.8	5.9	35	20	3.0	8.0	7.0	●				
neu	R/L P10.2010-20	2.0		1.0	5.9	35	20	4.0	8.0	7.0	●				
neu	R/L P10.2512-20	2.5		1.25	5.9	35	20	5.0	8.0	7.0	●				
neu	R/L P10.3015-20	3.0		1.5	5.9	35	20	6.0	8.0	7.0	●				

670...
676...
687...
...7

Weitere HM Sorten können Sie in der Sortenübersicht im Kapitel "Technische Hinweise" und der Preisliste finden.

Bestellbeispiel:
für rechte Ausführung und Sorte
RP10.1005-10/P04C

More carbide grades you can find in the grades summary in the chapter "technical instructions" and in the price list.

order-example:
righthand version and grade
RP10.1005-10/P04C