

ULTRAMINI

Bohrungsbearbeitung
ab $\varnothing 0.2$ mm

grooving, boring and profiling
starting at $\varnothing 0.2$ mm

Typ UM600H

High-Performance-Klemmhalter
mit Kühlmittelsanschluss

high-performance toolholder
with coolant connection

$\varnothing 12 - 28$ mm
für Schneideinsatz mit
D min. 0.2 - 7.0 mm

$\varnothing 12 - 28$ mm
for insert with
D min. 0.2 - 7.0 mm

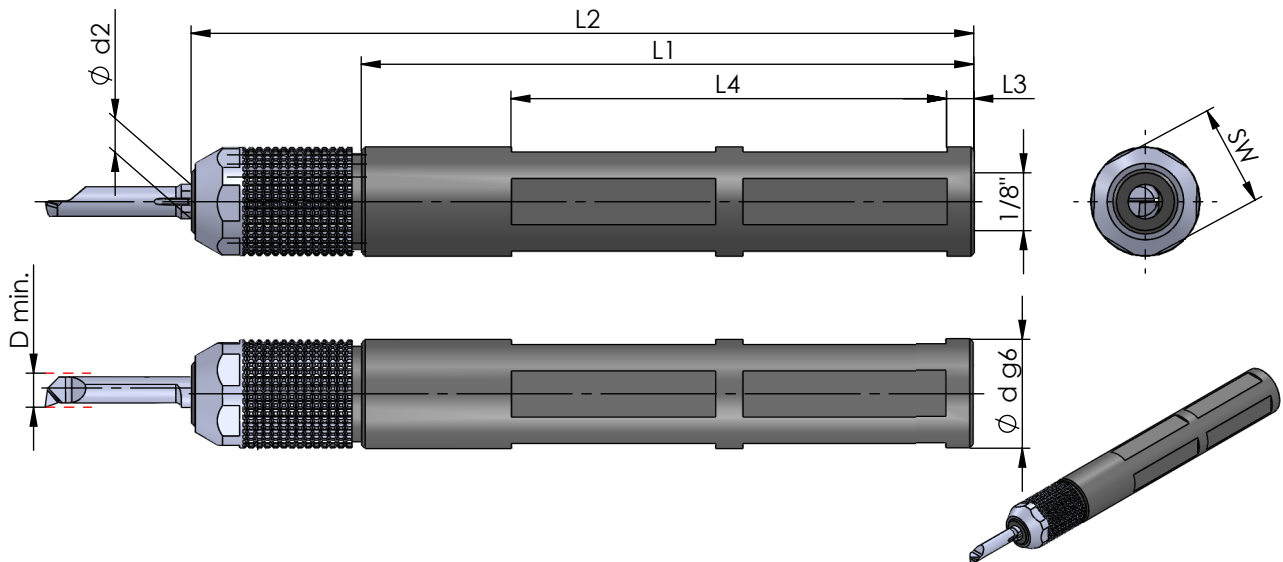

Klemmhalter für rechte und linke
Schneideinsätze einsetzbar

toolholder for right and left
inserts usable

Abmessungen in mm

dimensions in mm

Bestellnummer part number	$\varnothing d$ g6	$\varnothing d$ (inch)	L2	L1	L3	L4	Überwurfmutter union nut	Klemmkeil nut	$\varnothing d2$	$\varnothing d$ h6 Schneideinsatz insert
									\leq	
UM600H.0012.4	12		115	90	4	64	UM600H.M4	UM600H.K	4	
UM600H.0012.5	12		115	90	4	64	UM600H.M5	UM600H.K	5	
UM600H.0012.6	12		115	90	4	64	UM600H.M6	UM600H.K	6	
UM600H.0012.7	12		115	90	4	64	UM600H.M7	UM600H.K	7	
UM600H.0016.4	16		115	90	4	64	UM600H.M4	UM600H.K	4	
UM600H.0016.5	16		115	90	4	64	UM600H.M5	UM600H.K	5	
UM600H.0016.6	16		115	90	4	64	UM600H.M6	UM600H.K	6	
UM600H.0016.7	16		115	90	4	64	UM600H.M7	UM600H.K	7	

↳ ...

Merkmale:

- Handspannung ohne zusätzlichen Schlüssel
- Wiederholgenauigkeit $\pm 0,005$ mm (hohe Präzision)
- einfachste Bedienung
- ideal bei engen Platzverhältnissen
- Spannung mit Standardschlüssel SW15 möglich
- bei Einsatz von Rückwärtsdreher oder Hochdruckkühlung muss mit Schlüssel gespannt werden

characteristics:

- manual clamping without additional wrench
- continuous repeatability $\pm 0,005$ mm (high precision)
- simplest operation
- ideal where space is tight
- clamping by standard wrench SW15 is possible
- when backboring or high-pressure cooling you have to clamp with a wrench

Bestellbeispiel:
UM600H.0012.4

order-example:
UM600H.0012.4

ULTRAMINI

Bohrungsbearbeitung
ab Ø 0.2 mm

grooving, boring and profiling
starting at Ø 0.2 mm

Typ UM600H

High-Performance-Klemmhalter
mit Kühlmittelsanschluss

high-performance toolholder
with coolant connection

Ø 12 - 28 mm
für Schneideinsatz mit
D min. 0.2 - 7.0 mm

Ø 12 - 28 mm
for insert with
D min. 0.2 - 7.0 mm

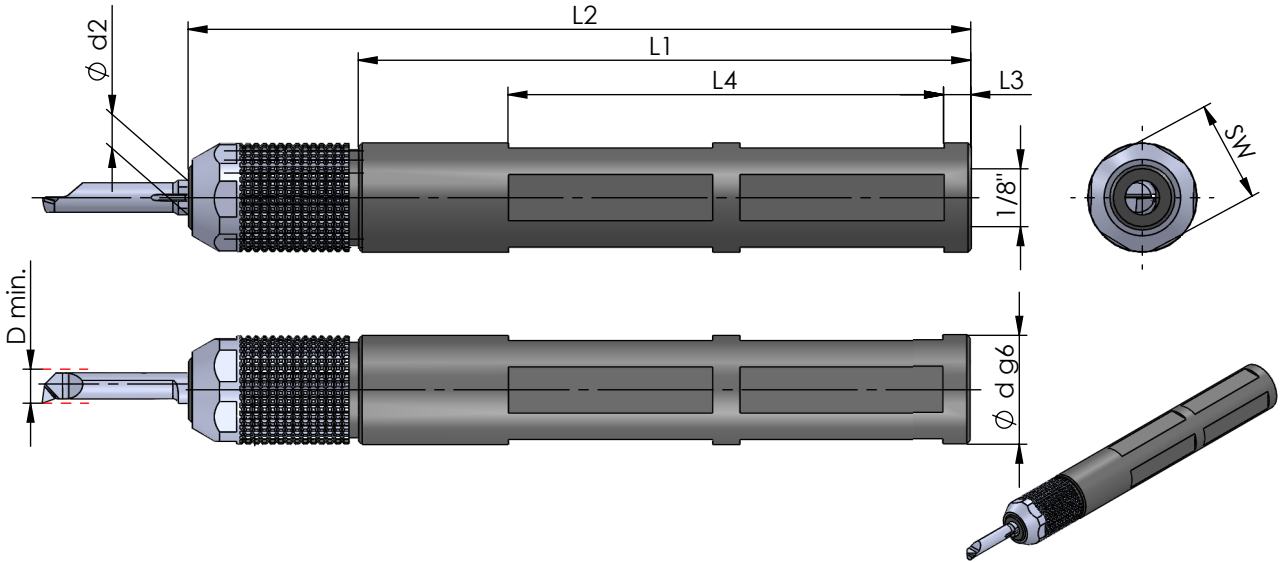

Klemmhalter für rechte und linke
Schneideinsätze einsetzbar

toolholder for right and left
inserts usable

Abmessungen in mm

dimensions in mm

Bestellnummer part number	Ø d g6		L2	L1	L3	L4	Überwurfmutter union nut	Klemmkeil nut	Ø d2 Ø d h6 Schneideinsatz insert
	Ø d (inch)								
...									
UM600H.001905.4	19.05	3/4"	115	90	4	64	UM600H.M4	UM600H.K	4
UM600H.001905.5	19.05	3/4"	115	90	4	64	UM600H.M5	UM600H.K	5
UM600H.001905.6	19.05	3/4"	115	90	4	64	UM600H.M6	UM600H.K	6
UM600H.001905.7	19.05	3/4"	115	90	4	64	UM600H.M7	UM600H.K	7
UM600H.0020.4	20		115	90	4	64	UM600H.M4	UM600H.K	4
UM600H.0020.5	20		115	90	4	64	UM600H.M5	UM600H.K	5
UM600H.0020.6	20		115	90	4	64	UM600H.M6	UM600H.K	6
UM600H.0020.7	20		115	90	4	64	UM600H.M7	UM600H.K	7
UM600H.0022.4	22		115	90	4	64	UM600H.M4	UM600H.K	4
UM600H.0022.5	22		115	90	4	64	UM600H.M5	UM600H.K	5
UM600H.0022.6	22		115	90	4	64	UM600H.M6	UM600H.K	6
UM600H.0022.7	22		115	90	4	64	UM600H.M7	UM600H.K	7
↳ ...									

Bestellbeispiel:
UM600H.001905.4

order-example:
UM600H.001905.4

ULTRAMINI

Bohrungsbearbeitung
ab $\varnothing 0.2$ mm

grooving, boring and profiling
starting at $\varnothing 0.2$ mm

Typ UM600H

High-Performance-Klemmhalter
mit Kühlmittelsanschluss

high-performance toolholder
with coolant connection

$\varnothing 12 - 28$ mm
für Schneideinsatz mit
D min. 0.2 - 7.0 mm

$\varnothing 12 - 28$ mm
for insert with
D min. 0.2 - 7.0 mm

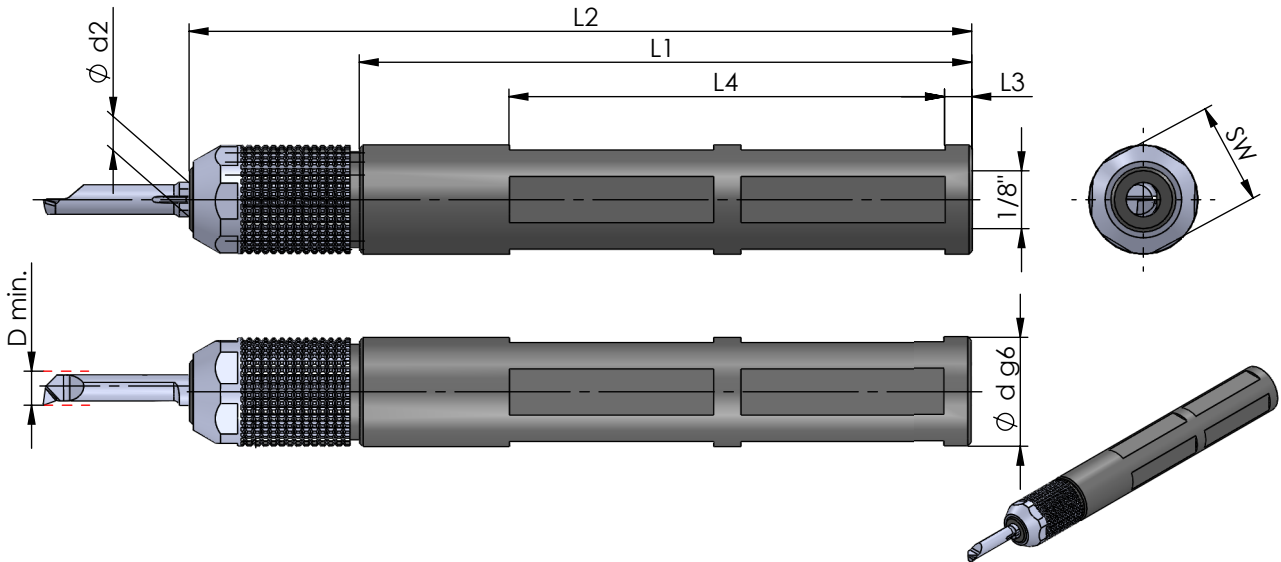

Klemmhalter für rechte und linke
Schneideinsätze einsetzbar

toolholder for right and left
inserts usable

Abmessungen in mm

dimensions in mm

Bestellnummer part number	$\varnothing d$ g6	$\varnothing d$ (inch)	L2	L1	L3	L4	Überwurfmutter union nut	Klemmkeil nut	Schneideinsatz insert	
									$\varnothing d2$	$\varnothing d h6$
...										
UM600H.0025.4	25		115	90	4	64	UM600H.M4	UM600H.K	4	
UM600H.0025.5	25		115	90	4	64	UM600H.M5	UM600H.K	5	
UM600H.0025.6	25		115	90	4	64	UM600H.M6	UM600H.K	6	
UM600H.0025.7	25		115	90	4	64	UM600H.M7	UM600H.K	7	
UM600H.00254.4	25.4	1"	115	90	4	64	UM600H.M4	UM600H.K	4	
UM600H.00254.5	25.4	1"	115	90	4	64	UM600H.M5	UM600H.K	5	
UM600H.00254.6	25.4	1"	115	90	4	64	UM600H.M6	UM600H.K	6	
UM600H.00254.7	25.4	1"	115	90	4	64	UM600H.M7	UM600H.K	7	
UM600H.0028.4	28		115	90	4	64	UM600H.M4	UM600H.K	4	
UM600H.0028.5	28		115	90	4	64	UM600H.M5	UM600H.K	5	
UM600H.0028.6	28		115	90	4	64	UM600H.M6	UM600H.K	6	
UM600H.0028.7	28		115	90	4	64	UM600H.M7	UM600H.K	7	

Bestellbeispiel:
UM600H.0025.4

order-example:
UM600H.0025.4