

Universal, grinding and inspection vices
 Étaux de contrôle et de rectification universel

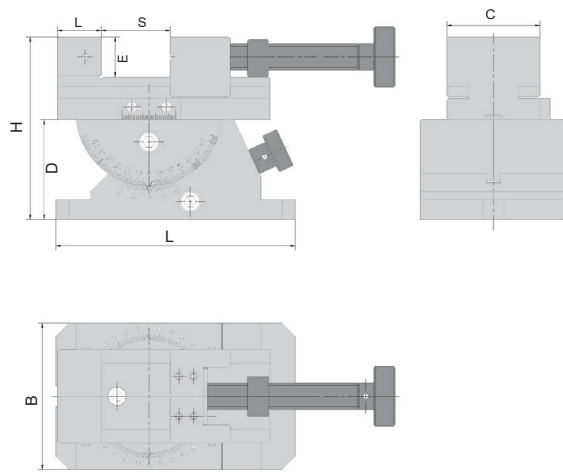
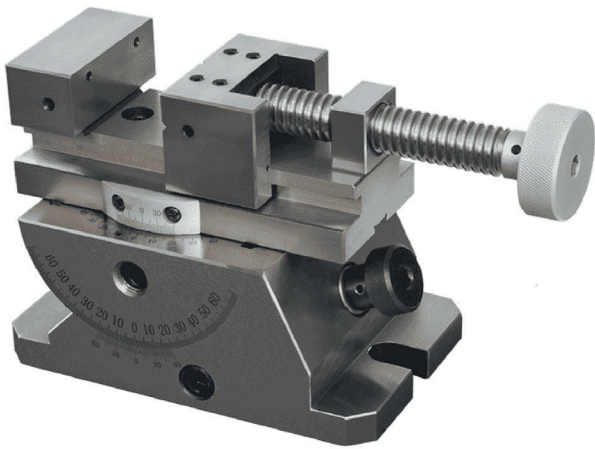

Bestell-Nr. Order no. Référence	B	H	D	E	C	S _{max}	L	kg
90.17.080	110	137	75	30	70	80	180	12

Bohrmaschinenschraubstöcke, mechanisch

Vices for drilling machines, mechanical
 Étaux pour machines à percer, mécanique

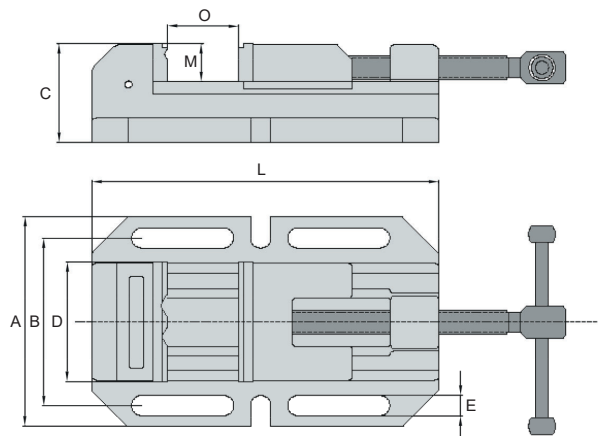

Bestell-Nr. Order no. Référence	Ausführung Version Version	A	B	C	D	E	L	O	M	kg
KS4080	MWM-80	141	111	50	80	11	152	70	22,5	2,3
KS4100	MWM-100	165	133,5	60	100	13,5	190	100	28,5	2,9
KS4150	MWM-150	220	182,5	70	150	15,5	250	150	28,5	5,7
KS4200	MWM-200	265	222,5	89	200	17,5	310	190	45,5	11,5